



**ULTRACARE**  
*At the Cutting Edge of Industry*

**SP 130**

**SLIDING TABLE PANEL  
SAW**

INSTRUCTION MANUAL No.3029/1



**SP 130**

**SLIDING TABLE PANEL  
SAW**

MACHINE No.	
TEST No.	
YEAR OF MANUFACTURE	

**MANUFACTURERS E.C. DECLARATION  
OF CONFORMITY**

The following machine has undergone "Conformity Assessment" and has undergone Third Party Examination by a Notified Body in accordance with:-

Schedule IV of the Supply of Machinery (Safety) Regulations 1992 and Amendment No. 2063

COMPANY

Wadkin Ultracare Limited  
Franks Road  
Hilltop Industrial Park  
Bardon  
Leicestershire  
LE67 1TT

RESPONSIBLE PERSON

Mr J P Smith (Director)

MACHINE DESCRIPTION

TYPE    Sliding Table Panel Saw

MODEL     SP 130

DIRECTIVES COMPLIED WITH

Supply of Machinery (Safety) Regulations 1992  
Amendment No. 2063 1994  
Draught Proposal CEN/TC 142  
ISO 9001 Part 1

NOTIFIED BODY

Lloyds Register  
Lloyds Register House  
29 Wellesley Road  
Croydon, CR0 2AJ

SIGNED ON BEHALF OF WADKIN  
ULTRACARE LTD.

EC TYPE EXAMINATION  
CERTIFICATE NO.



EC94/00011



## EC Type Examination Certificate

Certificate Number: EC 94/00011 A1

Office: UK Industry – Statutory Services

Date: 23 December 1994

*This is to certify that Lloyd's Register of Shipping, an Approved Body under the terms of; The Machinery Directive 89/392/EEC as amended by Directives 91/368/EEC, 93/44/EEC and 93/68/EEC as consolidated by Directive 98/37/EC. The Supply of Machinery (Safety) Regulations 1992, Statutory Instrument 1992 No. 3073 as amended by Statutory Instrument 1994 No. 2063 did undertake an EC Type Examination on the stated product for compliance with the essential safety requirements of the Directive. The product identified below was shown to comply. This certificate is issued to*

**APPLICANT**                      Wadkin Ultracare Limited,  
Green Lane Road,  
Leicester LE5 4PF,  
England.

**PRODUCT DESCRIPTION**                      Sliding Table Panel Saw

**TYPE**    SP130

*The attached LR Design Appraisal Document No. EC94/00011 issue 2 details the content of the Technical Construction File and shall form a part of this certificate.*

*“This Certificate is not valid for equipment, the design, ratings or operating parameters of which have been varied from the specimen tested. The manufacturer should notify LR of any modification or changes to the equipment in order to obtain a valid certificate.”*

.....  
**M.R. GREENHALGH**  
Surveyor to Lloyd's Register

**LR EC Distinguishing Number 0038**

**BE CAREFUL  
THIS MACHINE CAN BE DANGEROUS  
IF IMPROPERLY USED**

Always use guards.  
Keep clear until rotation has ceased.  
Always operate as instructed  
and in accordance with good practice.  
Read instruction manual before installing,  
operating or maintaining machine.

*Manufactured by : Wadkin UltraCare  
Franks Road  
Hilltop Industrial Park  
Bardon  
Leicestershire, LE67 1TT  
United Kingdom*

*Telephone No. : +44(0)870 850 9111  
Fax No. : +44(0)870 240 0575  
Website : [www.wadkinultracare.com](http://www.wadkinultracare.com)  
E mail : [info@wadkinultracare.com](mailto:info@wadkinultracare.com)*



## **PREFACE**

### **IMPORTANT**

**It is our policy and that of our suppliers to constantly review the design and capacity of our products. With this in mind we would remind our customers that while the dimensions and performance data contained herein are correct at the time of going to press, it is possible that due to the incorporation of the latest developments to enhance performance, dimensions and suppliers may vary from those illustrated.**

**This manual is written as a general guide. A typical machine is shown to illustrate the main features. For reason of clarity certain guards, safety devices and machine parts may not be shown on particular illustrations but **MUST** be fixed to the machine, correctly set and working before operating**

**Failure to comply with instructions in this manual may  
invalidate the guarantee**



---

## IMPORTANT

### SAFETY PROCEDURES AND CONSIDERATIONS

To ensure safe working conditions, persons operating and assisting with the operation of this machine must ensure that they read and fully understand the instructions given within this manual and have received sufficient training in the use of the machine and the safety aspects to be observed.

**Note:-** Persons under the age of 18 years must not operate the machine except during the course of training under the supervision of a trained operator.

#### A) POINTS TO NOTE BEFORE OPERATING OR ASSISTING WITH THE OPERATION OF THE MACHINE.

- 1) You have read and understand the operation and safety aspects of the machine and have been checked out by a qualified supervisor.
  - 2) The machine is supplied with full safe guarding. The machine shall not be operated unless the safe guardings are in position and are functional.
  - 3) Cutters/blades are the correct type, suitable for the machine and working conditions, rotate in the correct direction of cut, are sharp and correctly fitted.
  - 4) Correct spindle and speeds are selected for the cutter equipment and working conditions.
  - 5) Loose clothing is either removed or securely fastened back and jewellery removed.
  - 6) Adequate working space and lighting is provided.
  - 7) All dust extraction equipment is switched on, properly adjusted and working adequately.
  - 8) The machine is securely installed (refer to installation section within this manual).
  - 9) The machine should only be used for cutting wood or materials with physical and technological characteristics similar to wood, and for which the chip or particle removal process is similar.
-

**B) DURING MACHINING:-**

- 1) Wear suitable protective clothing e.g, approved eye protection, ear defenders and dust masks. Gloves shall be worn when handling sharp edge saws.
- 2) Stop the machine using the emergency stop or at the mains isolator before making adjustments, cleaning or carrying out maintenance.
- 3) Keep the floor area around the machine clean and free from wood refuse. Do not allow the floor around the machine to become slippery.
- 4) Stop the machine and report immediately to a person in authority any actual or potential malfunction or operator hazard. Do not attempt to repair or rectify the machine unless qualified or authorised to do so.
- 5) The operator must not leave the machine running whilst unattended.
- 6) Never by-pass interlocks.
- 7) A push stick or handled push block must be used to feed the trailing edge of a workpiece past the cutting blade.
- 8) When ripping never stand directly behind the material.

**WARNING:-**

Failure to observe correct operating procedures prior to and during operation of this machine can result in severe injury.

**DO NOT** attempt to operate the machine while under the influence of anything that reduces your alertness.

---



## HEALTH AND SAFETY

The CE mark on this machine signifies that an EC declaration of conformity is drawn up indicating that the machine is manufactured in accordance with the Essential Health and Safety Requirements of the 'Supply of Machinery (Safety) Regulations 1992'.

The 'requirements for supply of relevant machinery' in the General Requirement of the Regulations are not only that the machine satisfies the relevant essential health and safety requirements, but also that 'the manufacture.....carries out the necessary research or tests on components, fittings or the complete machine to determine whether by its design or construction the machine is capable of being erected and put into service safely'.

Persons who install this machine have duties under the 'Provision and Use of Work Equipment Regulations 1992'. An indication of these duties is given in the following extracts, but the user should be familiar with the full implications of the regulations.

REGULATION 5 requires that;

Every employer shall ensure that work equipment is so constructed or adapted as to be suitable for the purpose for which it is used or provided.

In selecting work equipment, every employer shall have regard to the working conditions and to the risks to health and safety of persons which exist in the premises or undertakings in which that work equipment is to be used and any additional risk posed by the use of that work equipment.

Every employer shall ensure that work equipment is used only for the operations for which, and under conditions for which, it is suitable.

In this regulation 'suitable' means suitable in any respect which it is reasonably foreseeable will affect health or safety of any person.

The Provision and Use of Work Equipment Regulations also include requirements as follows:-

regulation 6 - maintenance

regulation 7 - specific risks

regulation 8 - information and instructions

regulation 9 - training

### Note:-

Attention is drawn to those requirements of the 'Woodworking Machines Regulations 1974' which are not replaced by the Supply of Machinery (Safety) Regulations or other, eg; Regulation 13 of the Woodworking Machinery Regulation, - 'Training', still applies.

Whilst the prime duty for ensuring health and safety rests with employers, employees too have legal duties, particularly under sections 7 and 8 of the Health and Safety at Work Act. They include:

Taking reasonable care for their own health and safety and that of others who may be affected by what they do or don't do;

co-operating with their employer on health and safety;

not interfering with or misusing anything provided for their health, safety and welfare.

These duties on employees have been supplemented by regulation 12 of the Management of Health and Safety at Work Regulations 1992. One of the new requirements is that employees should use correctly all work items provided by their employer in accordance with their training and the instructions they receive to enable them to use the items safely.

---

## Noise

Noise levels can vary widely from machine to machine depending on the conditions of use. Persons exposed to high noise levels, even for a short time, may experience temporary partial hearing loss and continuous exposure to high levels can result in permanent hearing damage.

The Noise at Work Regulations 1989 place legal duties on employers to prevent damage to hearing.

There are three action levels of noise defined in regulation 2;

The first action level;-

a daily personal noise exposure ( $L_{EP,d}$ ) of 85dB(A)

The second action level;-

a daily personal noise exposure ( $L_{EP,d}$ ) of 90dB(A)

The peak action level

a peak sound pressure of 200 pascals (140dB re 20pa)

The exposure level is obviously influenced by the emission level of all the equipment in use.

Emissions levels for machines are provided in the particular machine instruction manual.

These levels are measured in accordance with ISO 7960 under certain specified test conditions, they do not necessarily represent the highest noise level, which is influenced by many factors, eg number of spindles in operation, type and condition of work piece, spindle speeds etc.

For regulations and information on relevant personal protective equipment i.e ear defenders, employers should refer to the Personal Protective Equipment at Work Regulations 1992.

## Dust

Wood dust can be harmful to health by inhalation and skin contact and concentrations of small particles in the air can form an explosive mixture.

The Control of Substances Hazardous to Health Regulations (COSHH) 1989 place legal duties on employers to ensure that;-

the exposure of his employees to substances hazardous to health is either prevented or, where this is not reasonably practicable, adequately controlled.

.....adequate control to exposure of employees to a substance hazardous to health shall be secured by measures other than the provision of personal protective equipment.

where the measures taken in accordance with the paragraph above do not prevent or provide adequate control of, exposure to substances hazardous to the health of employees, then in addition to tacking those methods, the employer shall provide those employees with such suitable personal protective equipment as will adequately control their exposure to substances hazardous to health.

## Instructions for Use

Machinery manufactures are required by the Supply of Machinery Safety Regulations to provide comprehensive "Instructions for Use" of equipment, it is important that this information is transmitted to the person using the machine.

## IMPORTANT

### SAFETY PROCEDURES AND CONSIDERATIONS

To ensure safe working conditions, persons operating and assisting with the operation of this machine must ensure that they read and fully understand the instructions given within this manual and have received sufficient training in the use of the machine and the safety aspects to be observed.

**Note:-** Persons under the age of 18 years must not operate the machine except during the course of training under the supervision of a trained operator.

- A) POINTS TO NOTE BEFORE OPERATING OR ASSISTING WITH THE OPERATION OF THE MACHINE.**
- 1) You have read and understand the operation and safety aspects of the machine and have been checked out by a qualified supervisor.
  - 2) The machine is supplied with full safe guarding. The machine shall not be operated unless the safe guardings are in position and are functional.
  - 3) Cutters/blades are the correct type, suitable for the machine and working conditions, rotate in the correct direction of cut, are sharp and correctly fitted.
  - 4) Correct spindle and speeds are selected for the cutter equipment and working conditions.
  - 5) Loose clothing is either removed or securely fastened back and jewellery removed.
  - 6) Adequate working space and lighting is provided.
  - 7) All dust extraction equipment is switched on, properly adjusted and working adequately.
  - 8) The machine is securely installed (refer to installation section within this manual).
  - 9) The machine should only be used for cutting wood or materials with physical and technological characteristics similar to wood, and for which the chip or particle removal process is similar.
-

**B) DURING MACHINING:-**

- 1) Wear suitable protective clothing e.g, approved eye protection, ear defenders and dust masks. Gloves shall be worn when handling sharp edge saws.
- 2) Stop the machine using the emergency stop or at the mains isolator before making adjustments, cleaning or carrying out maintenance.
- 3) Keep the floor area around the machine clean and free from wood refuse. Do not allow the floor around the machine to become slippery.
- 4) Stop the machine and report immediately to a person in authority any actual or potential malfunction or operator hazard. Do not attempt to repair or rectify the machine unless qualified or authorised to do so.
- 5) The operator must not leave the machine running whilst unattended.
- 6) Never by-pass interlocks.
- 7) A push stick or handled push block must be used to feed the trailing edge of a workpiece past the cutting blade.
- 8) When ripping never stand directly behind the material.

**WARNING:-**

Failure to observe correct operating procedures prior to and during operation of this machine can result in severe injury.

**DO NOT** attempt to operate the machine while under the influence of anything that reduces your alertness.

---

## CONTENTS

<b>SECTION 1 GENERAL INFORMATION</b>	<b>Page</b>
General Notes	1-1
Operator Working Positions	1-1
Noise Emission Values	1-2
Machine Specifications	1-5
Foundation and Machine Dimensions	1-7
<b>SECTION 2 UNLOADING, UNPACKING AND INSTALLATION</b>	
Unloading	2-1
Unpacking	2-1
Installation:-	
Location and foundation	2-2
Electrical supplies	2-2
Exhaust connections	2-3
Re-assembly of machine	2-3
<b>SECTION 3 OPERATING INSTRUCTIONS</b>	
General Information:-	
Safety	3-1
Safety devices	3-1
Controls	3-1
Mounting the Saws:-	
Main saw replacement/fitting	3-3
Scoring saw replacement/fitting	3-4
Machine Adjustments:-	
Main saw adjustment	3-5
Scoring saw adjustment	3-5
Riving knife adjustment	3-6
Rip fence adjustment	3-7
Fence plate adjustment	3-7
Crosscut fence, outrigger table and turnover stop	3-8
Sliding table	3-9
<b>SECTION 4 MAINTENANCE</b>	
General Notes	4-1
Regular Maintenance and Lubrication	4-1
Checking and Adjusting Drive Belt Tension	4-2
Tensioning or Replacing Scoring Saw Drive Belt	4-2
Machine Alignments and Settings	4-3
Replacing Friction Disc in Brake Motors	4-4
Approved Lubricants	4-7

---



---

## SECTION 5 ILLUSTRATED PARTS LIST

Rip Fence	5-3
Riving Knife Assembly	5-5
Rise and fall Assembly	5-7
Canting Assembly	5-9
Spindle Assembly	5-11
Drive Motor and Mounting	5-13
Sliding Table	5-15
Turn-over Stops	5-17
Handles and Lock for Sliding Table	5-19
Manual Clamp	5-21

---

## SECTION 1 GENERAL INFORMATION

The working of the SP130 panel saw is generally a one man operation although an assistant is usually necessary to off load the material when ripping.

The panel saw may be used with a 300mm or a 250mm blade. As well as the main saw, the machine comes complete with a driven scoring saw which rotates in the opposite direction but may only be used in conjunction with the 250mm saw blade.

The scoring saw makes a shallow cut to the underside of the panel before the main saw cuts through and thus eliminates breakout to the bottom face.

The type of work which may be carried out are:-

- a) **Ripping** using rip fence as guide or straight edge ripping using hold down plate.
- b) **Cross cutting** using sliding table and cross cut fence e.g panel sizing or angle cutting with crosscut fence pivoted to suit.
- c) **Angled cutting** with saw blade tilted. The trunnion bracket carrying the saws may cant up to 45 degrees.
- d) **Compound angles.** With the blades canted and the crosscut fence angled intricate compound angles may be cut.

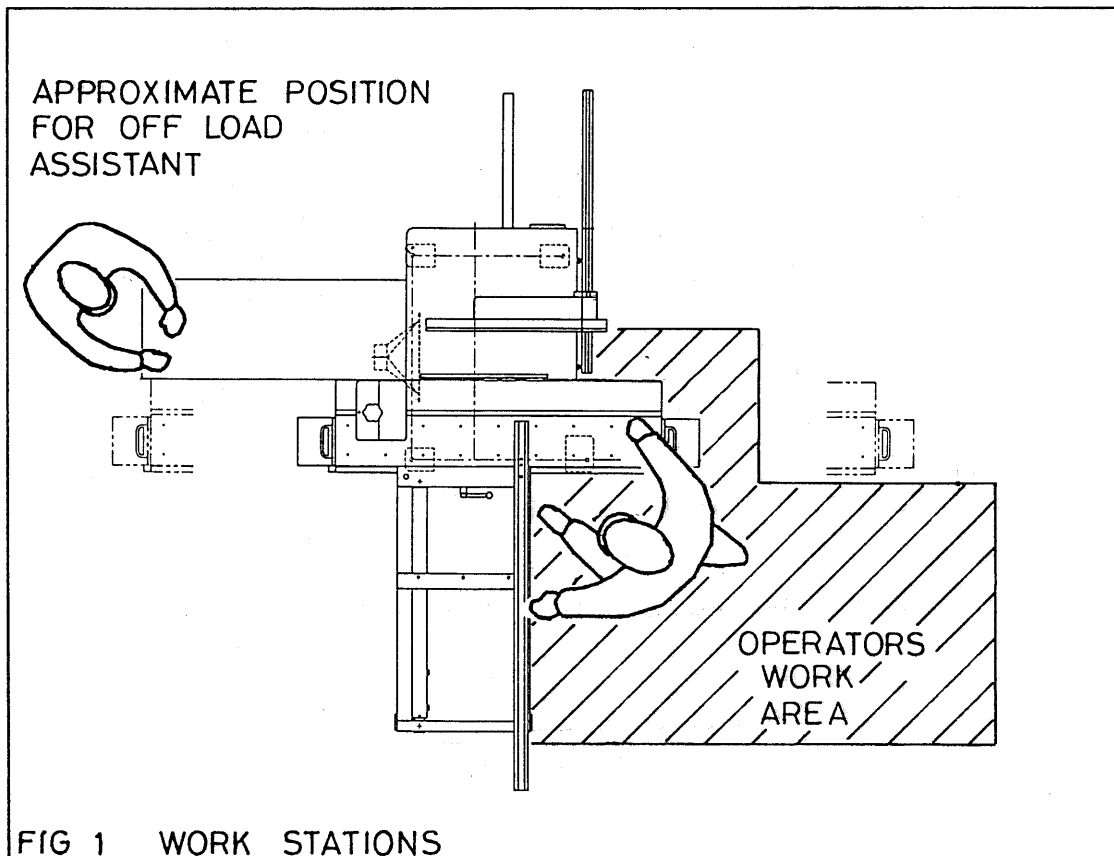

## NOISE EMISSION VALUES

### Machine criteria

The machine was free standing on a concrete floor, not bolted down and not mounted on any vibration dampening.

A flexible pipe connected the machine to the dust extraction.

There was no enclosure around the machine.

### Machine cutting criteria

The machine was fitted with a 300mm main saw rotating at 3800 R.P.M. The saw blade had 48 carbide tipped teeth and a cutting width of 3.2mm. The blade thickness was 2.2mm.

No scoring saw was used.

Feed rate:- 4-8 M/min

Cut width:- 50mm

Saw blade projection:- 30mm

### Material criteria

Material :- particle board  
(3 layer construction)

Moisture content:- 6-10%

Board thickness:- 16mm

Board length:- 800-600mm  
processed down  
to final width  
of 150mm.

Preliminary machining:- none

The figures quoted in the noise emission chart are emission levels and are not necessarily safe working levels.

Whilst there is a correlation between emission levels and exposure levels, this cannot be used reliably to determine whether or not further precautions are required to achieve safe working levels.

Factors that influence the actual level of exposure to the work force include the duration of exposure, the characteristics of the work room, sources of noise etc i.e the number of machines and other adjacent processes. also the permissible exposure levels can vary from country to country.

Emission levels, however will enable the user of the machine to make a better evaluation of the 'hazard and risk'.

### Tooling criteria

The SP130 panel saws have been designed to accept 250mm or 300mm diameter saw blades suitable to fit on a 30mm spindle.

The saw should have a 'pin hole' location.

Only use 300mm diameter saws when the scoring saw is not fitted. Never exceed the specified maximum speed of the saw blades.

NOISE EMISSION CHART		
MODEL:- SP TYPE :- 130 50HZ 415V		
DECLARED NOISE EMISSION VALUES in accordance with ISO4871		
	Idling	Operating
Declared A-weighted sound power level (L <sub>WAD</sub> ) in dB re l <sub>pw</sub>	85.86	94.92
Declared A-weighted emission sound level (L <sub>pAd</sub> ) in dB re 20uPa at the operators position	74.25	83.30
Environmental correction factor (K)	= 3	
values determined according to specific test code IS7960 Annex A		



Wadkin supplied riving knives are marked as to their saw blade suitability and the operator should ensure that the knife and blade are compatible.

Only tools made in conformity to pr EN847-1 shall be used on the machine.

It should also be noted that H.S.S saw blades may be prohibited by law in certain countries and the operator should ascertain the position on this point.



## MACHINE SPECIFICATION SP130

Max panel size	1300mm x 2500mm	(51" x 98")
Sliding table size	340mm x 1300mm	(14" x 51")
Fixed table size	680mm x 610mm	(34" x 24")
Max diameter of main saw	300mm	(12")
Max diameter of main saw when scoring	250mm	(10")
Max timber thickness when scoring	30mm	(1 <sup>3</sup> / <sub>16</sub> ")
Scoring saw diameter	105mm	(4")
Projection of 300mm main saw at 90 degrees	50-100mm	(2-4")
Projection of 250mm main saw at 90 degrees	25-75mm	(1-3")
Main saw spindle diameter	30mm	
Scoring saw spindle diameter	20mm	
Main spindle speeds	3850rpm	
Scoring saw spindle speed	7000rpm	
Main saw motor	2.2KW	(3HP)
Main saw motor option	3.7KW	(5HP)
Length of cut with sliding table	1300mm	(51")
Distance from saw to stop on cross cut table	2500mm	(98")
Max distance from saw to rip fence	914mm	(36")
Floor space	3000mm x 3800mm (118" x 150")	
Under saw extraction outlet diameter	100mm	(4")
Crown guard extraction diameter	80mm	(3 <sup>5</sup> / <sub>32</sub> )
Total dust extraction rate	1298CM/H	
Air velocity (suitable for timber moisture content of above 18%)	28M/S	
Nett weight approx	350 kg	(771LBS)
Gross weight approx	5200kg	(1146LBS)

**NOTE:-** For dry or nearly dry timber i.e moisture content below 18% the air velocity may be reduced to 20 M/S giving a total extraction rate of 927CM/H.

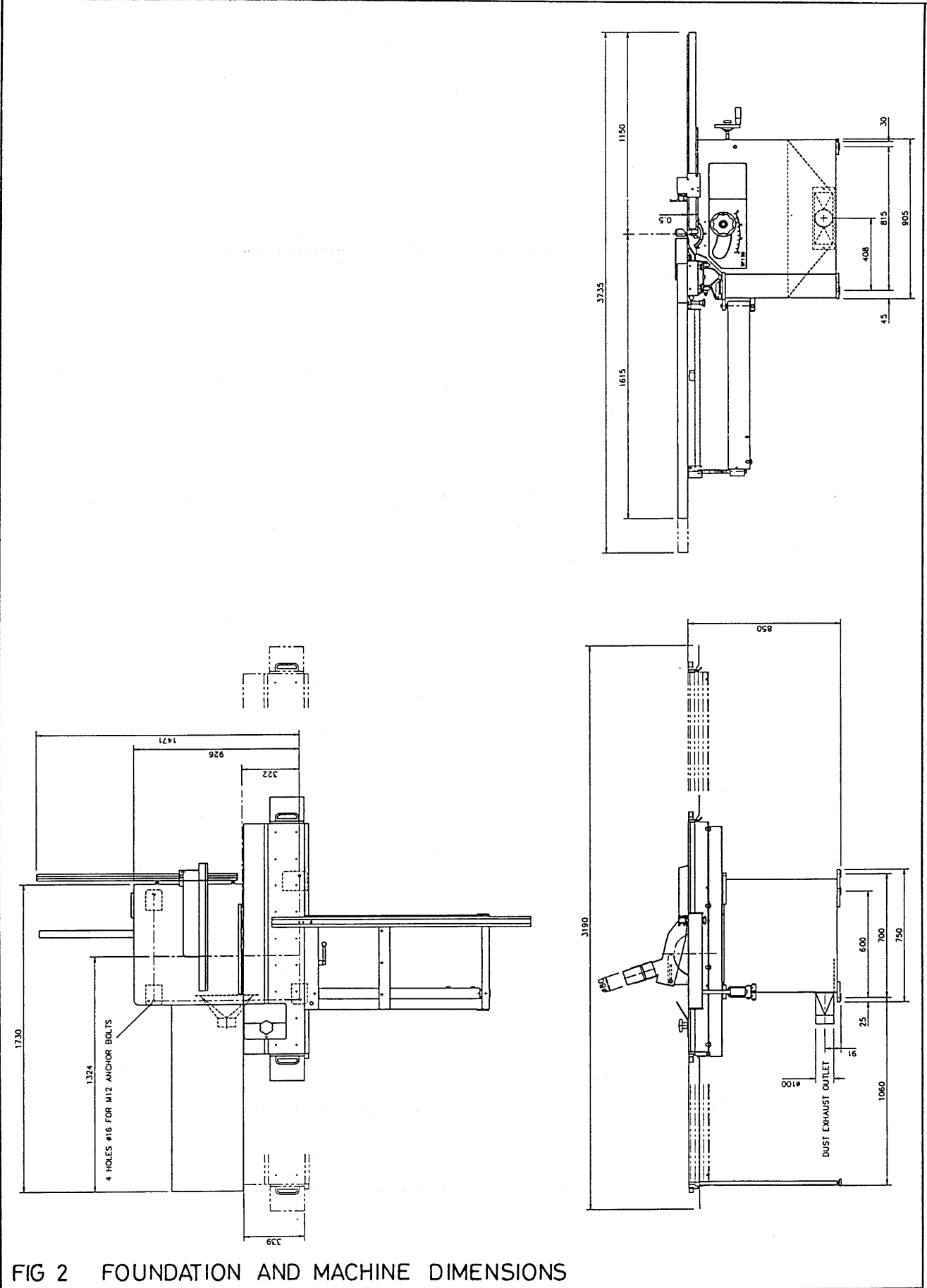

FIG 2 FOUNDATION AND MACHINE DIMENSIONS

## SECTION 2 UNLOADING , UNPACKING AND INSTALLATION

### Unloading (Fig 1)

Verify the weight of the machine (see **Machine Specification** ) and check that lifting equipment used is capable of lifting this weight as a minimum.

The machine leaves the factory fitted to a wooden pallet which allows for lifting and movement by a forklift. Alternatively slings may be positioned through the pallet or as illustrated.

**WARNING:-** Never walk or stand under a raised machine.

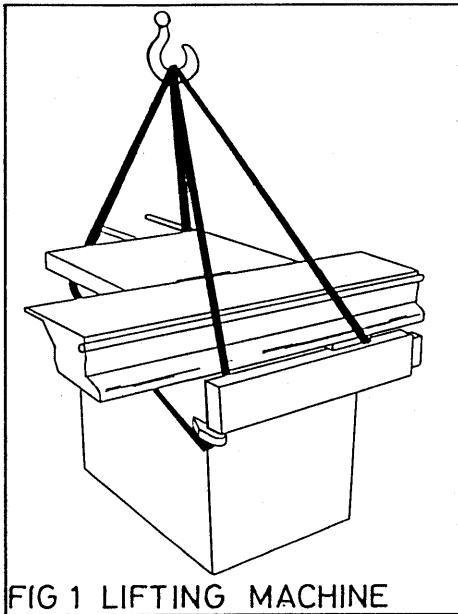

### Unpacking

To reduce the size of the machine for transport several items have been removed and individually packed. These items as well as the main body should be unwrapped and checked to make sure no damage has occurred in transit and to ascertain that the machine is complete with all fittings.

Check delivered items against the following list :-

**NOTE;-** Extras or customer special parts will not be listed and should be checked against order.

Outrigger table  
Turnover stops - 2 off  
Crosscut fence  
Main saw  
Scoring saw  
Saw guard  
Riving knives  
Rip fence guide bar  
Rip fence body  
Rip fence  
Rear extension table (optional)  
Legs for above - 2 off

Tool kit comprising of:-  
Push stick (C.E machines only)  
Instruction manual  
13mm A/F spanner  
32mm A/F spanner  
17/19mm A/F double ended  
spanner  
8mm long arm allen key  
6mm 'T' bar allen key  
5mm allen key  
4mm allen key

### Cleaning

Before levelling the machine carefully remove the anti-rust material, particularly from the bright areas.

Clean the machine with paraffin or diesel and a soft rag. Do not use a substitute as it may precipitate an explosion.

## Installation

For machine dimensions and specifications refer to **Section 1 General Information**.

### *Location and Foundation*

To obtain the best results from the 'Wadkin' woodworking machine, it is important that the floor on which the machine is to stand has been prepared, is dry and level.

The panel saw should be so placed that the traffic of men and materials to and from the machine fits smoothly into the general production flow.

The operators normal working position should be away from the aisle, so as not to cause a hazard. The minimum clearance on each working side of the machine should be at least 1 metre greater than the maximum capacity.

The machine **MUST** be secured to the floor before use.

Rawbolts M12 size and large M12 washers may be used.

When machine is secured the M10 support screw must be lowered into contact with the floor.

### *Electrical Supplies*

The customer is responsible for an adequate electrical supply. Details of power requirements are provided with the machine.

The machine is delivered with its complete electrical equipment ready for connection.

The electrical connection and schematic diagram are found in the electrical control cabinet as well as within the manual. The only connection to make is the power supply to the disconnect (isolator) switch.

## POINTS TO NOTE WHEN CONNECTING THE POWER SUPPLY.

- a. Check the voltage, phase and frequency correspond with those on the machine name plate.
- b. Check the main fuses are of the correct capacity in accordance with the machine nameplate details.
- c. Connect the incoming supply leads to the appropriate terminals.
- d. Check the saw rotation is correct. The main saw should rotate towards operator and the scoring saw the opposite way.

To reverse the rotation of drive, reverse any two of the line lead connections at the incoming supply after having first isolated the machine at the mains.

**WARNING:-** Electrical work must be carried out by a qualified electrician.

*Exhaust (Dust Extraction) Connections.*

The machine has two dust extraction points, one at the rear for the base and the other on the saw guard.

Both outlets should be connected via a length of flexible pipe (suitable to cater for the adjustments) to the main duct.

The flow of air to the exhaust outlets should be approximately 20 metres per second.

The volume of extracted air is 12.4 cu.metres/min. (436 cu.ft/min).

*Re-assembly of machine.*

Once the machine body has been properly sited and secured, remove the three lifting eyes and re-assemble in the following order:-

- 1) Mount main saw onto spindle (see **section 3**).
- 2) Fix and adjust riving knife (refer to **section 3**).
- 3) Mount scoring saw onto spindle (see **section 3**).

**NOTE:-** Only fit scoring saw if 250mm diameter main saw blade is fitted.

- 4) Fit saw guard.

- 5) Re-fit outrigger table by first positioning the outrigger table saddle (1) over the round bar on sliding table. Lower and locate outrigger table (2) onto swinging arm pivot (3). Tighten cam lock (4).

**NOTE:** Whilst this can be done by a single person, the operation is simplified with two.

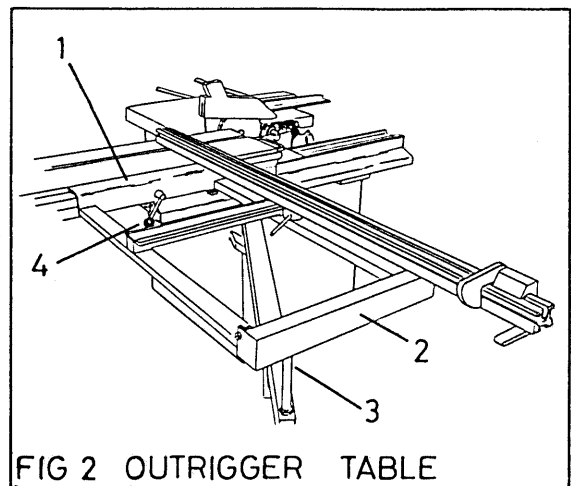

FIG 2 OUTRIGGER TABLE

- 6) To re-assemble the crosscut fence (11) first locate fence spigot (5) into the outrigger table saddle (1) ensuring fibre washer (6) is fitted between fence and saddle and that the fence lock (7) will be the correct side of the angled rule (8). Screw securing pin (9) with washer (10) in place. Fence is fastened in position by locking handle (7) which clamps fence to scaled angle rule (8).

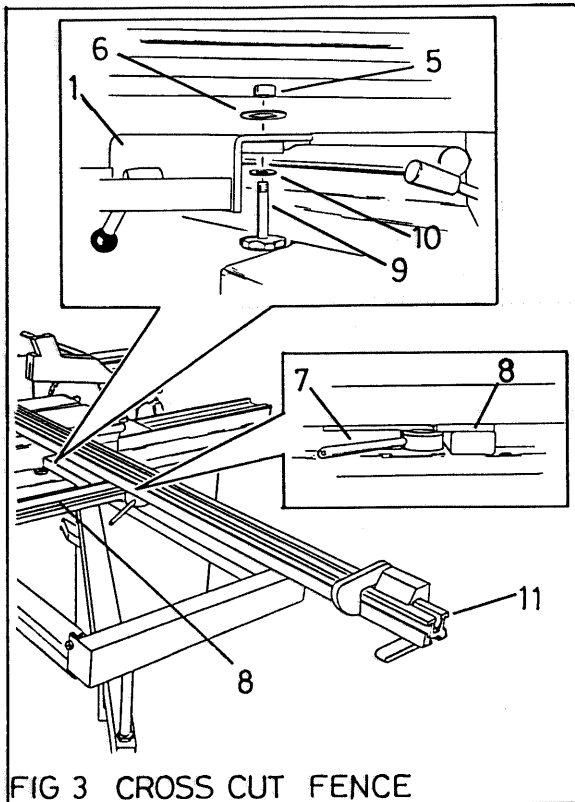

FIG 3 CROSS CUT FENCE

- 7) Slide turnover stops (12) onto crosscut fence (11) engaging clamp shoe (13) in side fence groove. Position to suit and turn knob (14) to lock.

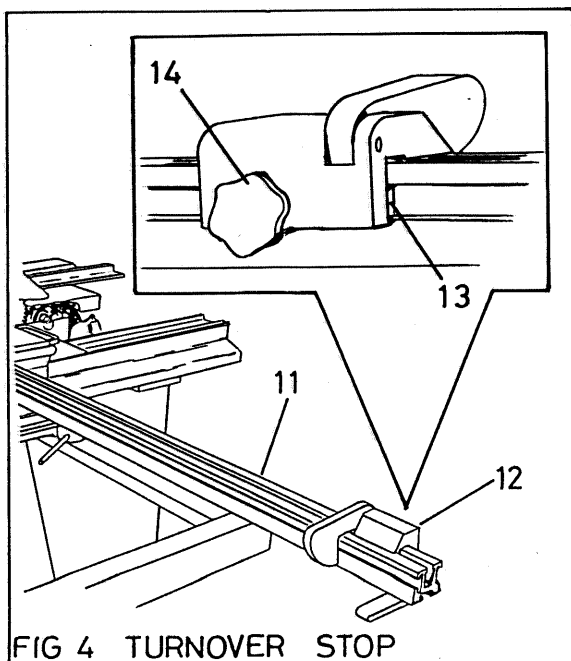

FIG 4 TURNOVER STOP

- 8) If supplied with rear extension table fit the legs and adjustable feet before loosely fastening the extension table to the main table. The securing holes in the extension table are slotted to allow for adjustment. By placing a straight edge on the main table, projecting over the rear extension table and using these slots in conjunction with the adjustable feet the tables may be levelled.  
When set tighten table bolts.

- 9) The first part of the rip fence assembly is the fitting of the rip fence guide bar (15) and support bar (16).

**NOTE:-** These bars are generally only removed on export machines.

Push the guide bar mounting studs through the relevant holes in the main table (17) and loosely secure with M16 locknuts.

**IMPORTANT:**

The two rear locknuts on each stud **must not** be moved as they are factory set to ensure the guide bar is square to the saw.

Set the rail level with the table top using a straight edge and tighten nuts.

- 10) Offer rear support bar (16) up to table and loosely fasten in position with M10 bolt and tapered washer.

Place a straight edge on the table projecting over the rear support bar. The securing bolt hole is drilled eccentrically in the end of the bar and by rotating the bar it can be levelled to the table. Once set tighten the bolts ensuring the bar does not move.

- 11) Slide rip fence body (17) onto the support bar and tighten lock handle. (18). Screw stop bolt (19) in end of bar and fit rip fence (20).

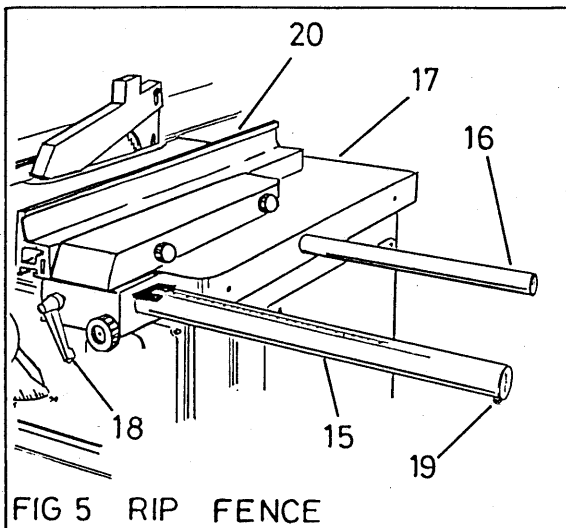



## SECTION 3 OPERATING INSTRUCTIONS

### GENERAL INFORMATION

#### Safety

The safe operation of woodworking machinery requires the constant alertness and close attention to the work in hand.

**Read this instruction manual in it's entirety before operating the machine.**

Blunt saws often contribute to accidents. An efficient machinist knows when sharpening is necessary, but if there is a reluctance to spend time on sharpening then instead of cutting efficiently and smoothly they will tend to chop and snatch at the workpiece. This not only increases the risk of accidents but also lowers the quality of work.

When choosing a saw blade ensure it is suitable for the machine, material and saw speed.

Never raise the saw guard until the blade has come to rest.

#### Safety Devices (Fig 1)

All guards must remain in position whilst the saw is rotating.

The emergency stops located on the machine can also act as safety stops and must be engaged before working near components that can rotate i.e., saw blades, belts.

The removable cover (1) on the under table/saw guard may be interlocked (2) to the saw motor and in these instances the guard cannot be removed until the saw is stationary.

A push stick when provided with the machine must always be used to push the trailing end of the timber past the saw. When not in use it should be relocated on it's support pegs.

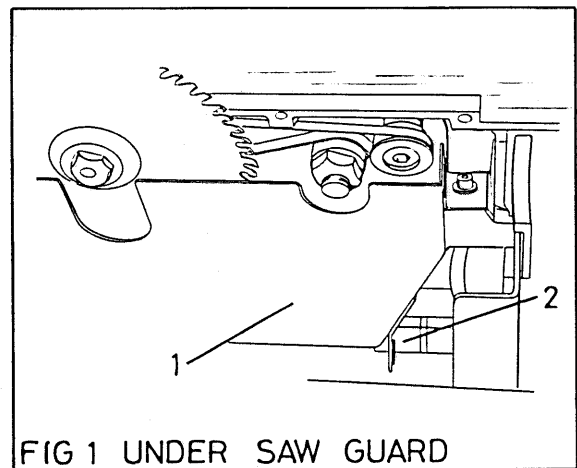

FIG 1 UNDER SAW GUARD

#### Controls (Fig 2)

Before starting the machine operators must familiarise themselves with the various controls, their usage and positions.

The rise and fall adjustment, the control panel and the isolator are found on the front face of the machine. When an interlocked under saw guard is fitted the main control box is positioned to the left under the beam. The saw blade cant is located on the right hand side of the machine.

The standard control box contains :-

- 1) MAIN SAW switch. Push to start saw (on under beam control box the switch is replaced by a green push button).

- 2) **MASTER STOP.** Push in to isolate power or stop machine, pull out to restore power. After restoring power to the machine the saws will not start until the main saw button is pressed again.

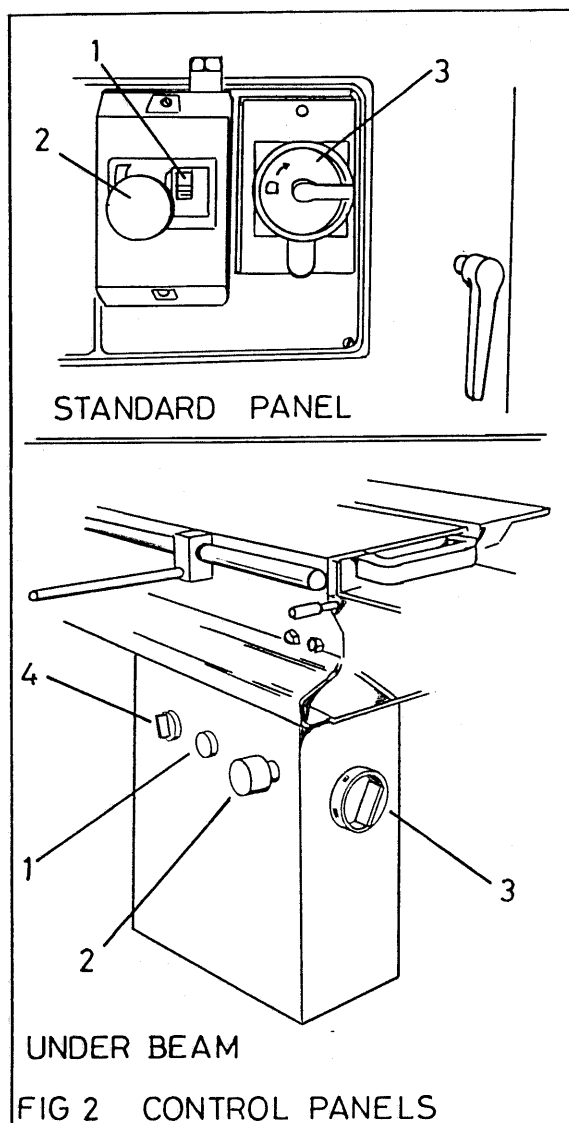

When the control panel is fitted under the beam it houses not only the saw start (1), the master stop (2) and the machine isolator (3) as described above but also the guard switch (4).

- 4) **UNDER SAW GUARD** switch. Locked to the right, unlocked to the left. The machine must be stopped via the emergency stop button and the blades must be at rest before turning the switch to the 'off' position and removing the guard. If the power is off at the main isolator the switch will not function.

A duplicate emergency stop and saw start may be fitted as an optional extra. This unit is fitted to the infeed end of the sliding table.

- 3) **MACHINE ISOLATOR** is located next to the control box and is in the 'on' position when the central bar of the switch is vertical. In the 'off' position it is possible, using a padlock, to immobilise the switch and prevent unauthorised use.

## MOUNTING THE SAWS

### Main Saw Replacement/Fitting (Fig 3, Fig 4)

- 1) Isolate power at emergency stop and allow saws to come to rest.
- 2) If fitted turn the under guard switch to the release position i.e to the left.
- 3) Raise saw to it's maximum setting.
- 4) Locate sliding table at it's maximum infeed position i.e at its full extent towards the operator, to allow clear access to both the saw positions.
- 5) Raise the guard (4) clear of the saws.
- 6) Slacken off under saw guard securing screws (if guard interlock is fitted the screws need to be removed).

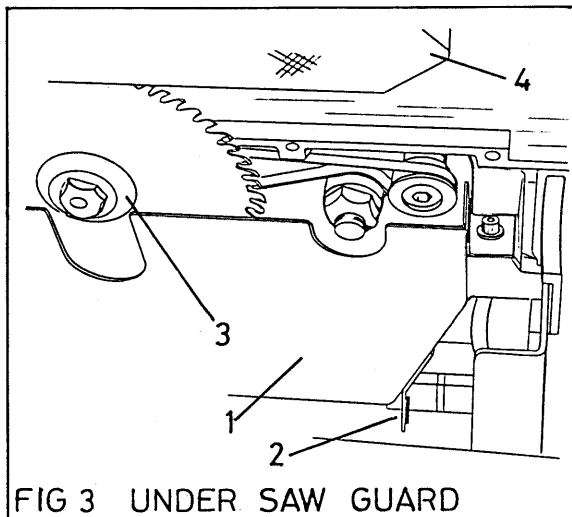

FIG 3 UNDER SAW GUARD

- 7) Lift guard clear (the interlock (2), when fitted, which prevents the under saw guard cover (1) from being removed has a time lock delay of between 10 and 20 seconds).

- 8) Locate and hold in position an 8mm allen key (5) in the hexagonal recess in the end of the main saw arbor. This will prevent the saw arbor rotating whilst the arbor nut (6) is being unscrewed using the supplied spanner.

After removing the arbor nut and the saw flange (3), the saw (7) (if fitted) may be removed.

**Note:** The arbor nut has a left hand thread and is released by turning clockwise.

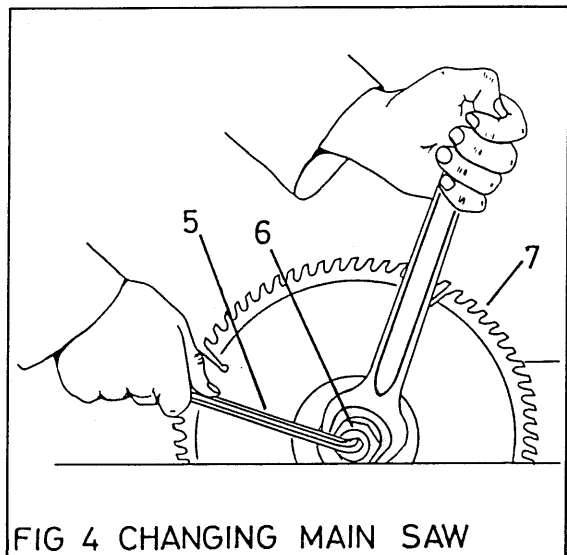

FIG 4 CHANGING MAIN SAW

- 9) Before re-fitting and securing new saw blade check the following:-
  - i) The saw is suitable for the machine and workpiece.
  - ii) Blade, saw flanges and arbor are clean.
  - iii) The saw is in good condition.
  - iv) The teeth are facing the correct way i.e., towards the operator (infeed).

- v) The riving knife is suitable for the blade size.
- 10) Replace saw flange (7) and tighten nut (6).
- 11) Check riving knife positioning, relevant to blade and if necessary adjust (refer to **Riving Knife Adjustment**)
- 12) Replace and secure under saw guard (1).
- 13) Position guard (4) to suit (refer to **Guard Adjustment**).
- 14) Reposition table and restore power by disengaging emergency stop.

#### **Scoring Saw Replacement or Fitting**

- 1) Follow steps 1-7 under Main Saw Replacement/Fitting.
- 2) Locate and hold in position, an 8mm allen key in the hexagon recess in the end of the scoring saw spindle. Slacken off and remove the saw nut using a 32mm A/F spanner. The saw spindle has a right hand thread and thus the nut should be rotated anti-clockwise to release.
- 3) Remove collar and saw (if fitted).
- 4) The scoring saw splits in halve to allow shims to be inserted. The supplied shims are as follows:-
  - Green shim. 003" (0.076mm)
  - Lilac shim. 005" (0.127mm)
  - Black shim. 010" (0.254mm)

The kerf (cutting width) of the scoring saw should be adjusted using these shims so as to equal or be slightly greater than the kerf of the main blade.

Both saws should have the kerf etched onto their blades.

**Note:** Ensure mating faces of scoring saw and shims are clean and free from dirt before assembling. Check location pegs between saw halves are properly engaged.

- 5) Place scoring saw onto the clean spindle with the teeth facing towards the main saw.
- 6) Replace collar and tighten nut.
- 7) Replace and secure under saw guard.
- 8) Position saw guard to suit workpiece.
- 9) Reposition table and restore power by disengaging emergency stop.

## MACHINE ADJUSTMENTS

### Main Saw Adjustment (Fig 5, Fig 6)

#### Height Adjustment

- 1) Slacken off locking knob (1).
- 2) Turn handwheel (2) clockwise to raise blade or anti-clockwise to lower. When the saw is canted at 45 degrees it is easier to adjust the blade height if the sliding table is moved to the rear of the machine.

**Warning:** Before attempting to set the blade to a specific height, against a rule for example, ensure emergency stop is pressed to isolate power and the saws are stationary.

- 3) When set refasten locking handle (1).
- 4) Set guard

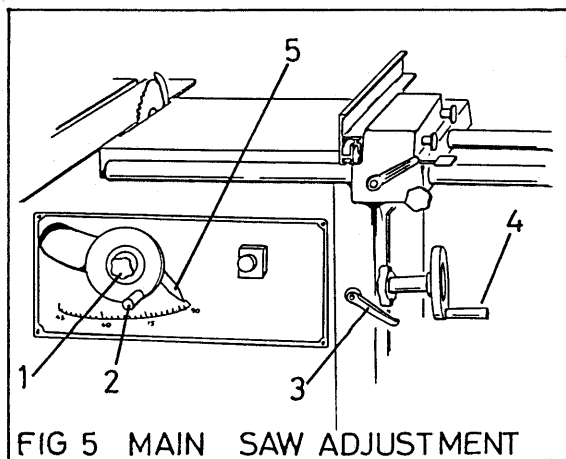

- 3) Rotate handwheel (4) clockwise to cant saw blade to the right (towards the rip fence). A scale pointer (5) indicates the angle of the saw blade.

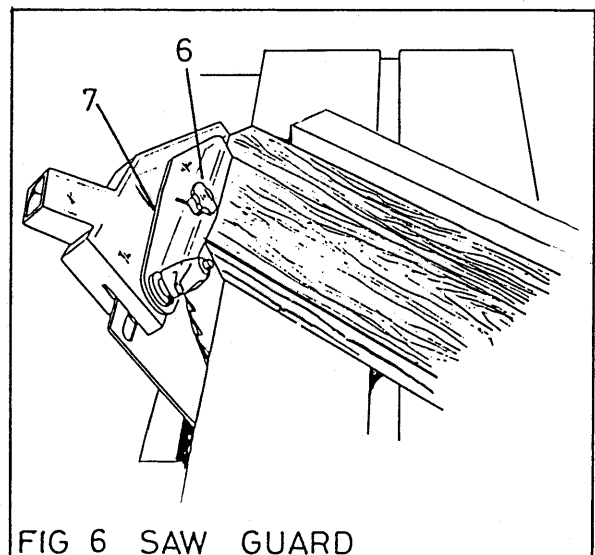

- 4) When set tighten locking handle (3).
- 5) Slacken off hand knob (6) and slide saw guard side cover (7) down to cover maximum amount of saw blade without interfering with timber passage. Tighten knob (6).
- 6) Restore power.

### Scoring Saw Adjustment (Fig 7, Fig 8)

#### Height Adjustment

The scoring saw and the main saw casting pivot about a point between the two spindles. Therefore as the main saw height increases the scoring saw starts to retract below the bed level.

#### Cant Adjustment

- 1) Isolate power at emergency stop and wait for blades to cease rotating
- 2) Release locking handle (3).

The scoring saw is mainly used on thinner materials and the maximum timber thickness that can be cut before the scoring saw becomes inoperative is 30mm.

### Lateral Adjustment

- 1) Isolate power at emergency stop and check blades are stationary before proceeding
- 2) Before laterally adjusting the scoring saw to align with the main saw ensure that the kerf of the scoring saw has been adjusted to suit main saw (see **Mounting Saws**).
- 3) Place a straight edge (1) across the main saw and projecting over scoring saw.

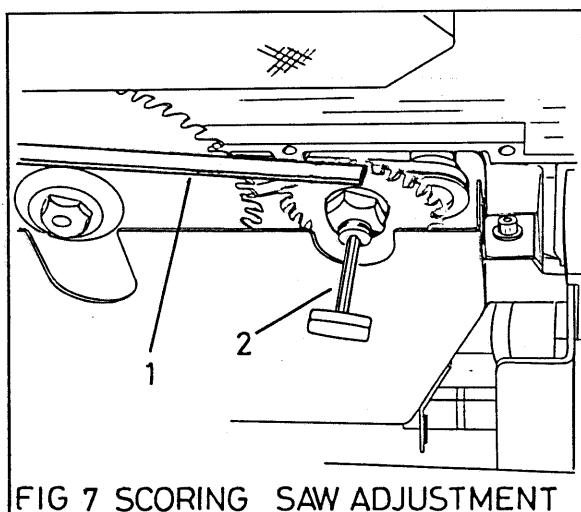

- 4) Place the 6mm 'T' bar allen key (2) into the end of the scoring saw spindle. A clockwise rotation moves the saw towards the rip fence. When correctly set both sides of the main saw should align or be equally offset with the respective sides on the scoring saw.

- 5) When correctly set remove 'T' bar allen key and straight edge.
- 6) Restore power.

### Riving Knife Adjustment (Fig 8)

- 1) Isolate power at mains or at master stop and allow sawblades to come to rest.
- 2) Raise guard and check riving knife (1) is suitable for the saw diameter.

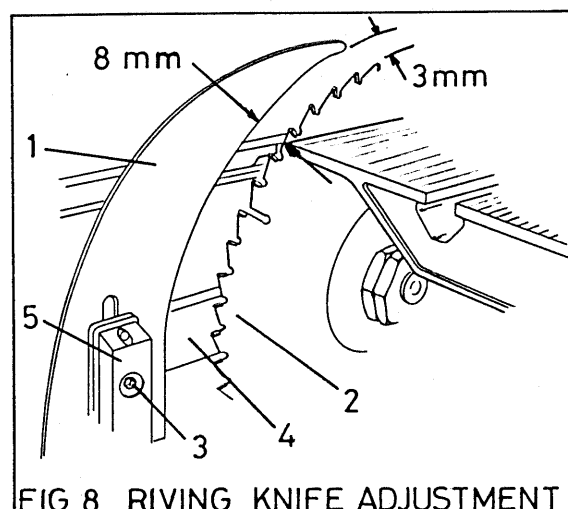

- 3) Slacken off the lock screw (3) and by sliding the clamp body (5) along the rail (4) and sliding the riving knife up or down, position riving knife so that at table level the gap between saw (2) and knife is a maximum of 8mm and the distance between the saw and the top edge of the knife is 3mm max or vice versa.
- 4) Tighten lock screw (3) reset saw guard and restore power.

### Rip Fence Adjustment (Fig 9)

The rip fence body slides on a round support bar fitted to front of the machine and is supported by a second bar at the rear. Rapid adjustment or small micro adjustments are both catered for.

#### Rapid Adjustment

- 1) Loosen locking handle (1)
- 2) Using scale pointer (2) and reading off scale (3) position rip fence to suit.

**NOTE;-** If the fence plate orientation has been changed the pointer (2) will need to be recalibrated (see **Fence plate adjustment**).

- 3) Tighten handle (1).

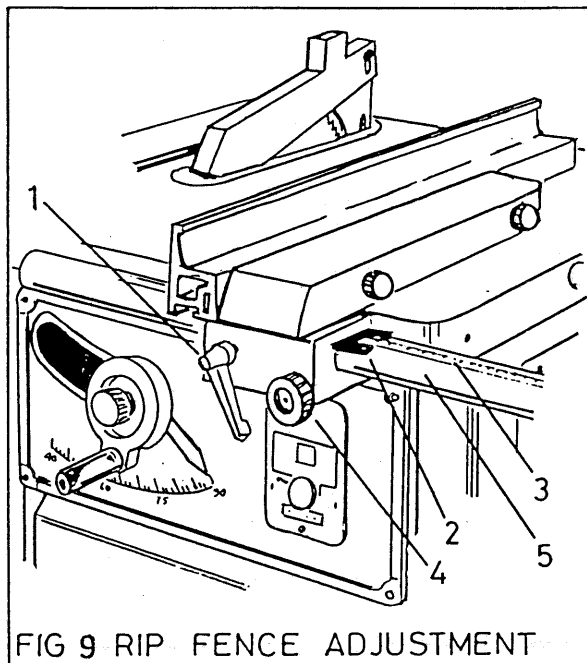

FIG 9 RIP FENCE ADJUSTMENT

#### Micro Adjustment

- 1) Loosen locking handle (1).

- 2) The micro adjustment knob (4) is sprung loaded and when pushed in and turned it engages a rack fitted to the under side of the support bar (5).

- 3) After adjustment tighten handle (1)

### Fence Plate Adjustment (Fig 10)

The fence plate may be fitted in two different positions. In the upright position (as illustrated) the fence can be used for deep stock material, whilst in the alternative setting it may be used when machining panels, small components, etc.

If the orientation of the fence is altered then the scale pointer must be recalibrated.

#### Horizontal Adjustment

- 1) Loosen hand wheels (1) and slide fence plate to required position.

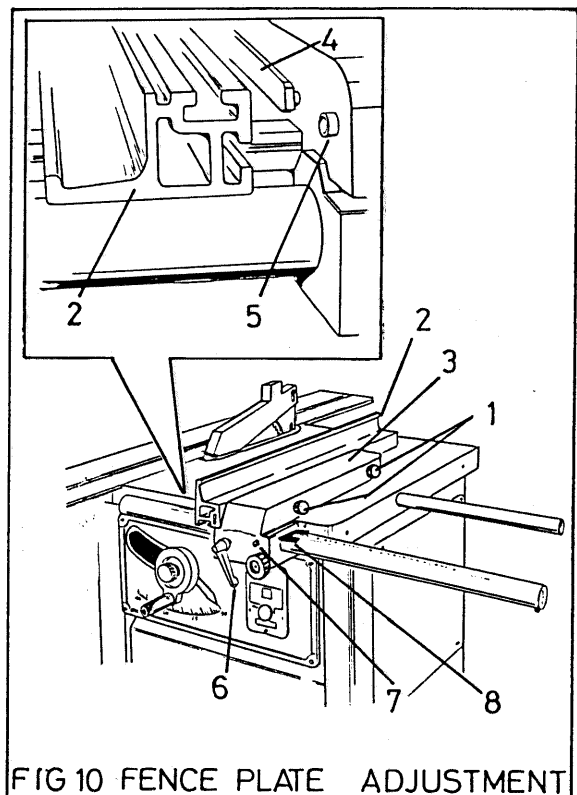

FIG 10 FENCE PLATE ADJUSTMENT

- 2) Tighten hand wheels (1).

#### *Position Change of Fence Plate*

- 1) Slacken off hand wheels (1).
- 2) Slide fence plate (2) from body (3).
- 3) Turn to alternative working face and slide 'T' slot over the locking plate (4) and guide collars (5).
- 4) Position horizontally to suit and then tighten hand wheels (1).

#### *Fence Pointer Adjustment*

- 1) Loosen locking handle (6) and move fence to a position which would allow a reasonably cut to be taken. Lock in position.

- 2) Start machine and using fence plate as a guide pass a piece of timber through. Stop machine.
- 3) Accurately measure the timber, then slacken off the grub screw (7) and recalibrate pointer (8) accordingly.
- 4) Relock grub screw.

#### **Crosscut Fence, Outrigger Table and Turnover Stop (Fig 11)**

The crosscut fence can pivot from either the rear (as illustrated) or front of the outrigger table to allow for mitre cuts.

#### *Setting for Mitre Cut*

- 1) Slacken off locking handle (1).

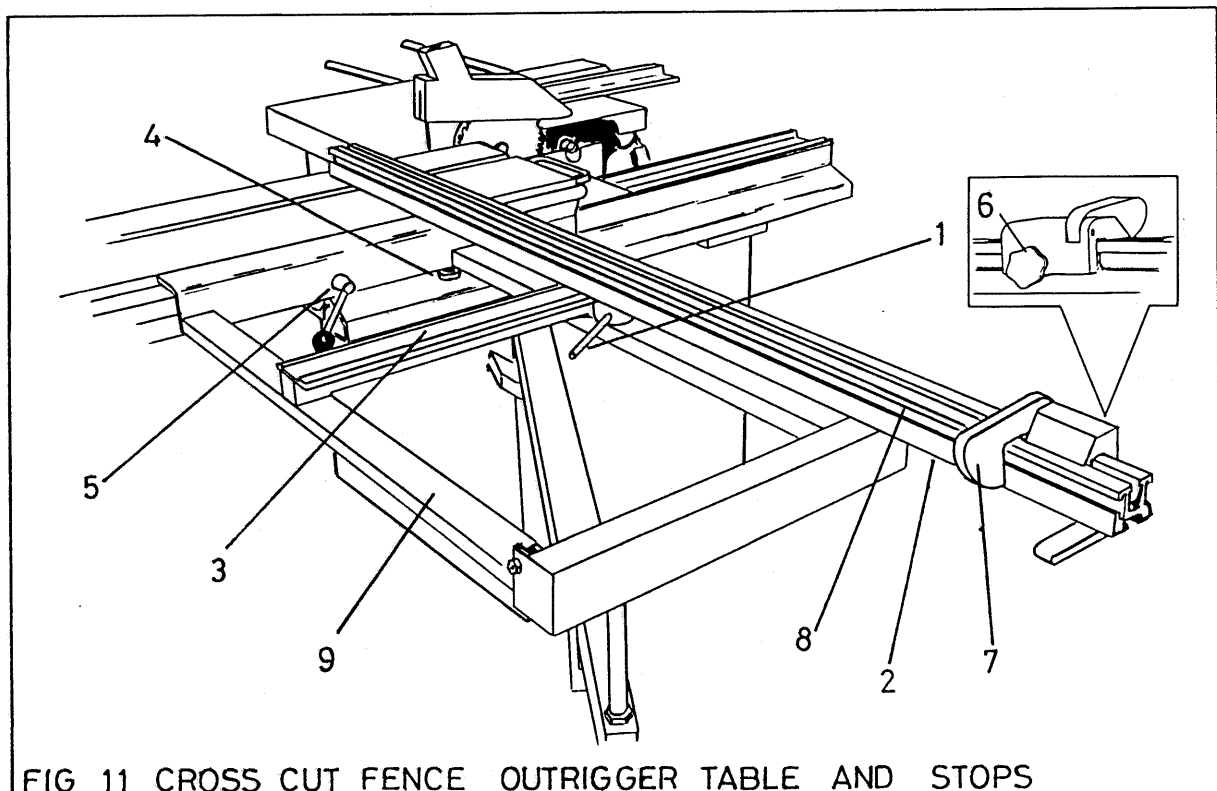

FIG 11 CROSS CUT FENCE OUTRIGGER TABLE AND STOPS



- 2) Pivot crosscut fence (2) until the infeed side of the fence aligns with the desired angle reading on the scale (3).
- 3) Tighten handle (1).

If the fence should need to be pivoted from the opposite point then both the locking handles (1) and (4) must be fully unscrewed and removed.

Re-position fence ensuring all spacers, washers etc., are correctly fitted and then refit handles.

#### *Outrigger Table*

The outrigger table (9) may be moved along the length of the sliding table to facilitate mitre/panel cuts by releasing locking handle (5)

#### *Turnover Stops*

Two turnover stops are fitted to the crosscut fence to enable timber to be positioned in the correct relationship to the sawblade and for repeat cuts of the same timber size.

- 1) To position stop slacken off locking handle (6).
- 2) Position stops at the desired setting by reading from the scale (8) set into the top of the crosscut fence. The reading should be taken at the inner face of the stop plate (7) i.e the face nearest the saw blade.
- 3) Tighten handle (6).

**Note:** The stop plate (7) may be pivoted to the opposite side depending on the angle of the fence.

#### **Sliding Table (Fig 12)**

The sliding table may be locked in certain positions to allow safe and easy handling of work.

Before locating large panels the table should be brought to the maximum forward position and locked by pushing handle (1) downwards.

**Note:** To allow the sliding table maximum forward movement the outrigger table should be set at the rear of the sliding table.

When the panel, stops, etc., are positioned the lock handle (1) may be released.

For ripping operations the table is normally locked in the mid position i.e., when sliding table and fixed runner base are directly above each other (as shown in illustration).

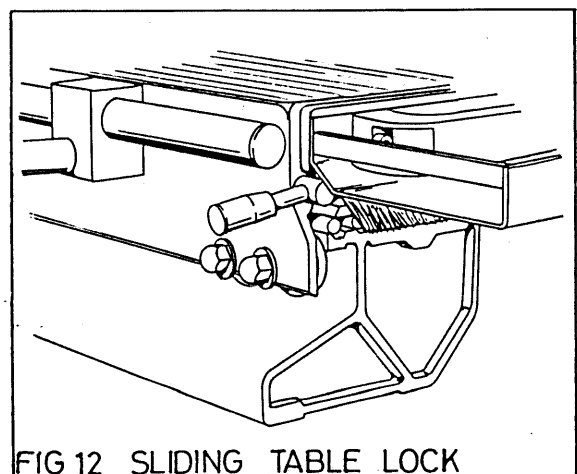

FIG 12 SLIDING TABLE LOCK

## SECTION 4 MAINTENANCE

The machine has been designed to keep the ease and scale of maintenance to a minimum.

Regular scheduled maintenance such as lubrication and cleaning should be carried out to ensure the machine is in a good operating condition and capable of safely producing good quality trouble free work with the minimum of downtime.

**WARNING;-** Always isolate power at master stop and allow saw blades to come to rest before carrying out any maintenance or lubrication.

### Regular Maintenance and Lubrication (Fig 1, Fig 2, Fig 3)

When a brake motor is fitted there will be a need to replace the friction disc within the brake unit. The replacement period varies depending on the frequency of stop/starting, however, when the stopping time of the motor starts to significantly increase the disc should be changed.

#### Weekly

Using a brush or similar method lightly lubricate with Wadkin grade L6 grease the following areas;-

- 1) Saw rise and fall slides (1)
- 2) Saw cant slides (2)
- 3) Screw threads for rise and fall (3)
- 4) Screw threads for canting shaft (4)

Each week to prevent resin/sawdust build up on sliding parts, screw threads, etc the machine should be traversed to all its limits

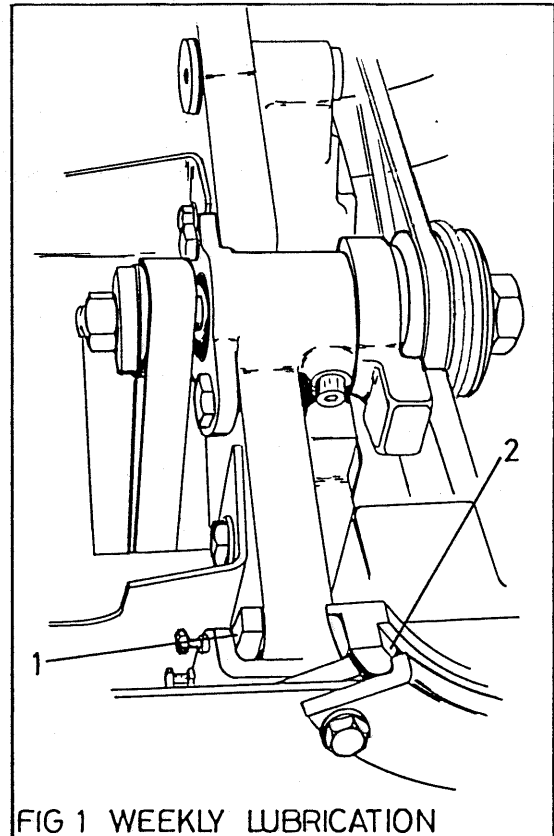

FIG 1 WEEKLY LUBRICATION

It is recommended that the machine be cleaned thoroughly each week. If cleaning with compressed air, take care not to point the jet directly at bearing housings, slide joints or pivots. Clean the spindles, collars, tables, fences and saw blades to remove all remains of resin and saw dust. Remove any saw dust from machine base.

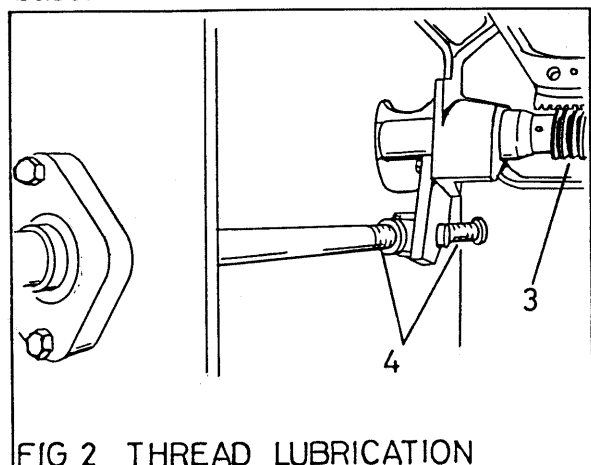
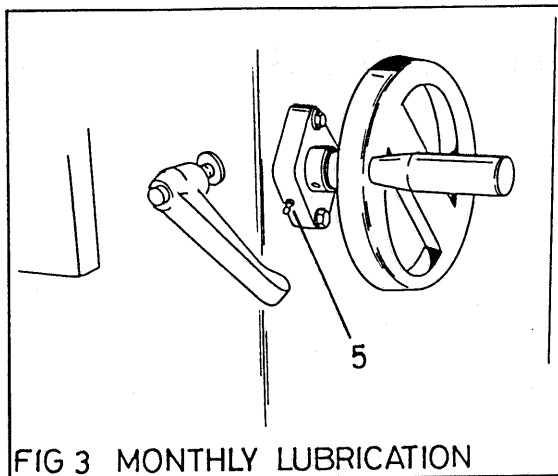

FIG 2 THREAD LUBRICATION

### Monthly

Using Wadkin grade L6 grease in a grease gun lubricate the rise and fall bearing housing (6).



### Three Monthly

Prior to scheduled lubrication clean all screw thread adjustments and slides with a resin based solvent.

After lubrication traverse screw threads and slides to their limits to ensure even and total coverage of lubricant.

Check condition and tension of drive belt.

Remove motor fan cowl, check condition of fan blades, remove any saw dust or shavings and replace cowl.

### Checking and Adjusting Drive Belt Tension (Fig 4)

The belt, at its correct tension, should be able to be depressed 8-10mm at the mid span by the application of an average thumb pressure of 22-31N (5-7 lbf).

### Adjustment

- 1) Check that power is isolated and that the blade is at rest.
- 2) Remove side panel by unscrewing the four securing hexagonal screws

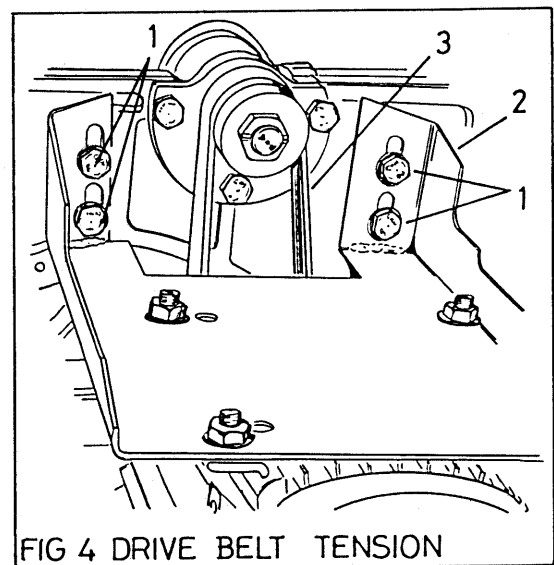

- 3) Loosen the four hexagon bolts (1) holding the motor support bracket (2).
- 4) Re-position bracket (3) on its slotted mountings until the belt is correctly tensioned.
- 5) Tighten bolts (1), replace and secure door and restore power.

### Tensioning or Replacing Scoring Saw Drive Belt (Fig 5)

The scoring saw is driven by a "poly vee" belt from the main saw spindle.

- 1) Isolate power at emergency stop and check saw blades are at rest.

- 2) Remove both saws (Refer to **Mounting Saws** Chapter 3)
- 3) Cant saw arbor to 45 degrees.
- 4) Remove access door near to cant winding handle.
- 5) Adjust belt tension from inside the machine by loosening locknut (1) with supplied spanner and then turning handle (2) clockwise to release tension or anti clockwise to increase.

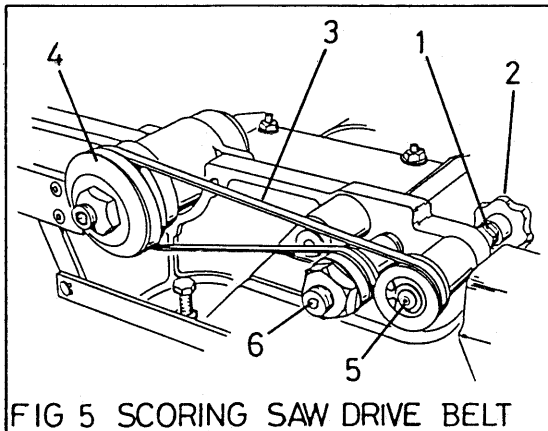

FIG 5 SCORING SAW DRIVE BELT

- 6) If replacing belt (3) remove the old one and refit the new belt with the grooves on the outside. The belt should pass around the main saw spindle (4) and the tensioner pulley (5) with the scoring saw spindle (6) pressing the lower span upwards.
- 7) Re-tension belt from inside of the machine by turning the handle (2) until the freeplay has been removed. Turn the handle a further 20-25 degrees to obtain the correct tension (the belt should feel reasonably tight).

- 8) Re-lock locknut (1), replace access door, re-fit saws and all guarding (re-setting if necessary)
- 9) Restore power

### Machine Alignments and Settings

Although the machine is factory set with regards to fences, saw alignment etc it may become necessary at a latter date to reset items due to part replacement for example.

#### Rip Fence Alignment (Fig 6)

The rip fence (4) should be set level with the table (see **Section 2 Installation**) and parallel to the blade. To set the rip fence the support bar (3) must be adjusted.

**NOTE:-** Never attempt to set rip fence square to saw blade by adjusting sliding table.

- 1) Isolate power and ensure blade is at rest.

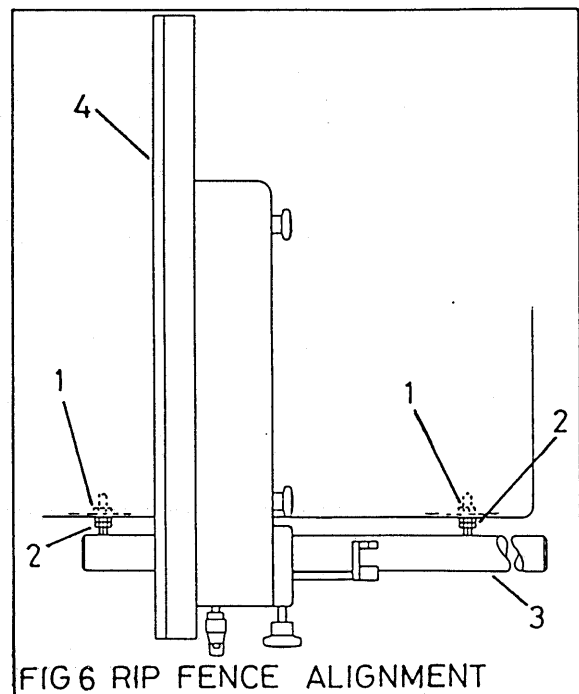

FIG 6 RIP FENCE ALIGNMENT

- 2) Slacken off the rear nuts (1) under the main table
- 3) Adjust the front locknuts (2) to suit.
- 4) When set re-tighten rear locknuts (1).

**NOTE;-** When a dial indicator is run along the machined 'T' slot, the rip fence should not be greater than 0.1mm out of parallel and the greater distance must always be at the outfeed side of the fence.

#### Setting Saw to Riving Knife (Fig 7)

- 1) Isolate power and visually check saw blade is not rotating

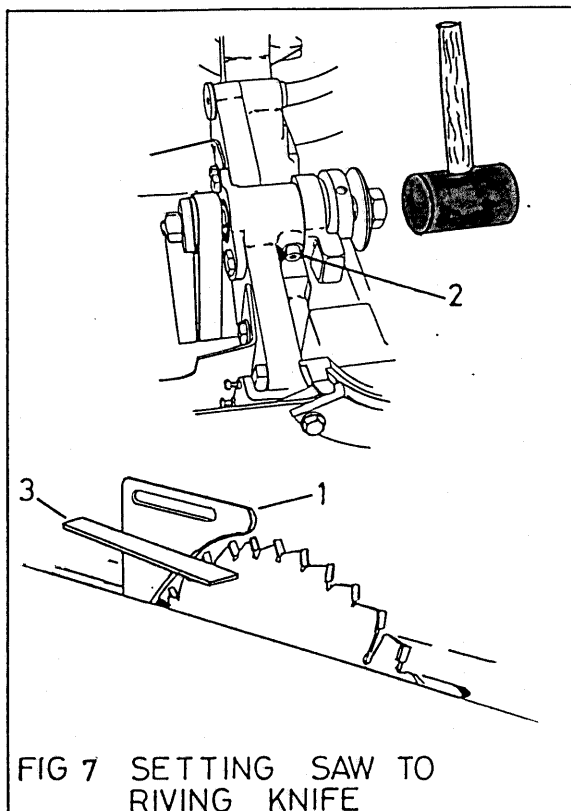

- 2) Loosen socket head capscrew (2)

- 3) Place a straight edge (3) along one side of the riving knife (1), projecting over the teeth of the saw blade and using feelers measure the gap between the two. Repeat this on the other side of the riving knife.
- 4) Using a soft faced mallet gently tap the spindle in the necessary direction to equalise the gap either side of the knife.
- 5) When set tighten capscrew (2).
- 6) Restore power.

#### Replacing Friction Disc in Brake Motors (Fig 8)

- 1) Isolate power at main isolator.
- 2) Remove side panel by unscrewing the four securing hexagonal screws.
- 3) Remove cowl from motor.
- 4) Remove motor fan. Depending on the type and size of motor the fan may be held onto the shaft by tension pins or grubscrews. It may also be keyed
- 5) Remove the four fixing screws (5) holding the brake in position and withdraw unit from the hub.
- 6) The rear mounting flange (1) has two locking tabs (2) on opposite corners which need to be slightly bent back to allow the unit to be separated.
- 7) With the tabs opened up rotate the rear flange (1) and the front magnet system (3) in opposite directions. This separates the unit and exposes the friction disc (4).

8) Replace disc (4).

**NOTE:-**

The friction disc has a protruding boss at one side of the toothed bore, ensure when installing the new disc, that this boss is situated at the mounting flange (1) side of the brake.

9) To re-assemble, reverse the dismantling procedure, then ensure the locking tabs are fully re-clamped. Visually centralise the disc toothed bore by thumb pressure, then re-mesh onto the motor shaft. Re-secure flange with screws (5), re-place and secure fan and cowl.

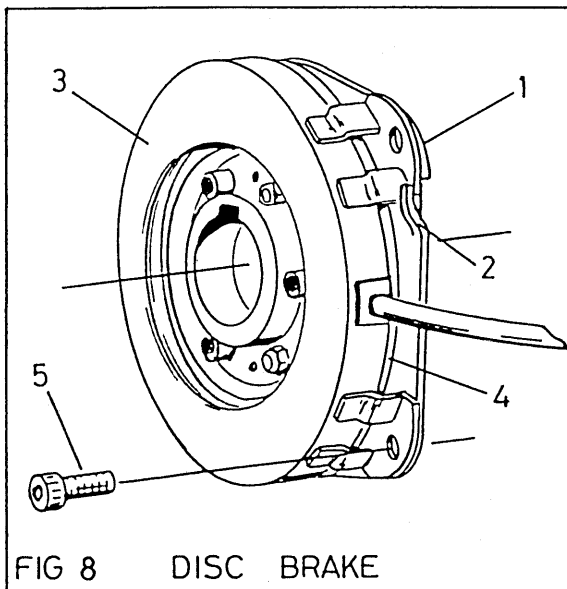

## APPROVED LUBRICANTS

WADKIN	CASTROL	B.P	SHELL	MOBIL	ESSO	GULF	CALTEX
L1	Hyspin AWS 32	energol HLP 32	Tellus 37	DTE oil Light 24	Nuto H32 43 AW	Harmony Oil HDA	Rando
L2	Alpha ZN 150	Energol HP 150	Vitrea 150 or CS 150	Vactra Extra	Spartan EP 150 Heavy	Service 13	URSA P40
L4	Magna 68	Energol HP 68	Vitrea 68 or CS68	Vactral Oil	Nurray 68 Heavy Medium	Service 51	URSA P20
L6	Spheerol AP3	Energrease LS3	Alvania Grease No 3	Mobilplex Grease No 48	Beacon 3	Gulfcrown Grease No 3	Regal Startak Premium 3

L1 Oil                      Hydraulic oil with anti-corrosion, anti -oxidation, anti wear, anti-foam performance.

L2 Oil                      Gear oil (viscosity 150 centi-stokes at 40 degrees c).

L4 Oil                      Plain mineral oil (viscosity 68 centi-stokes at 40 degrees c).

L6 Grease                Grease NLG1 No3 consistency lithium bearing grease.



---

## SECTION 5 ILLUSTRATED PARTS LIST

### CONTENTS

1. Rip Fence
2. Riving Knife Assembly
3. Rise and Fall Assembly
4. Canting Assembly
5. Spindle Assembly
6. Drive Motor and Mounting
7. Sliding Table
8. Turn-over Stops
9. Handles and Lock for Sliding Table
10. Manual Clamp



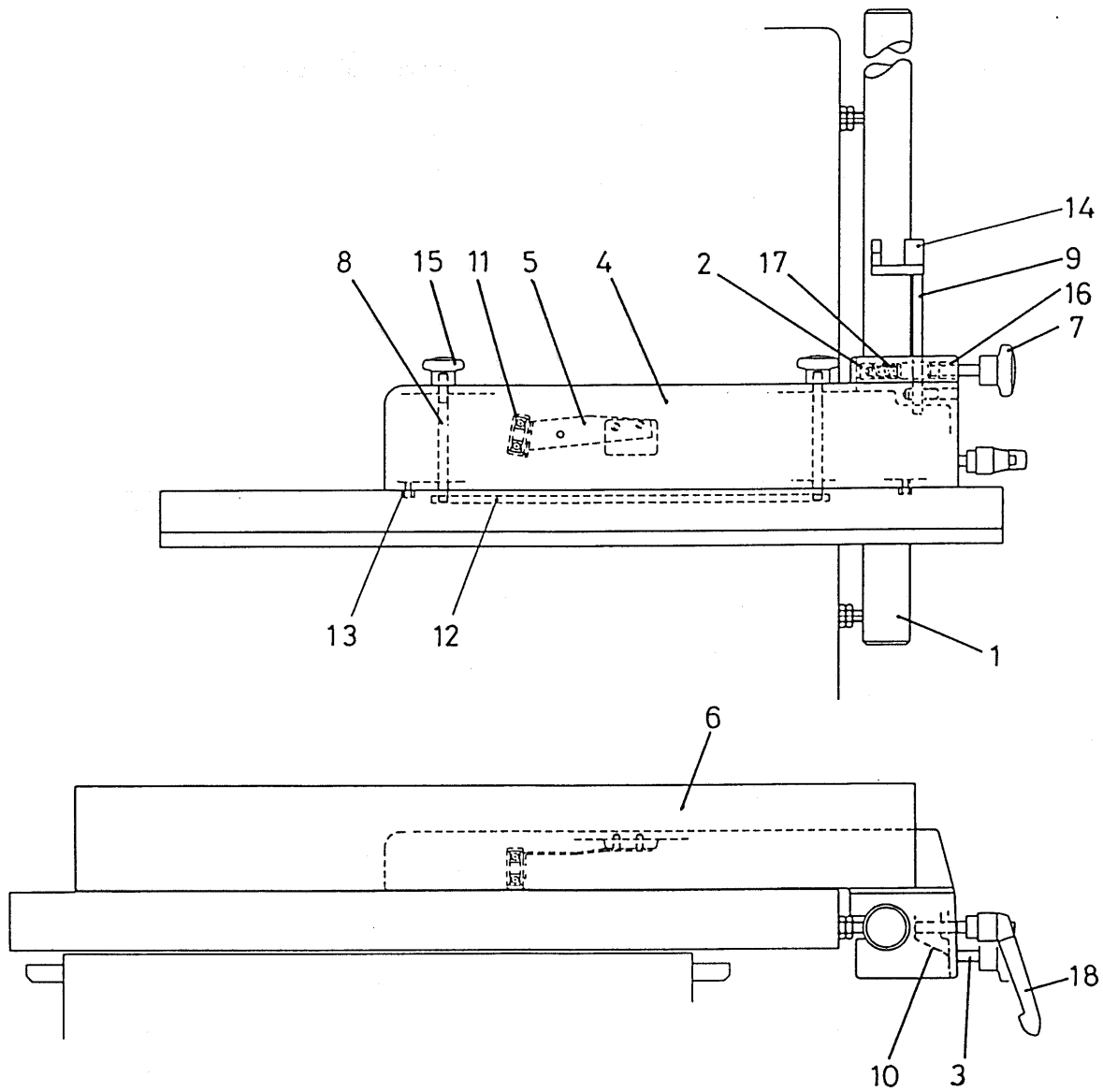

FIG 1 RIP FENCE



## 1. RIP FENCE

Ref No	Description	No Off
1.	Fence bar	1
2.	Retainer	1
3.	Pinion	1
4.	Rip fence	1
5.	Spring	1
6.	Fence plate	1
7.	Handwheel	1
8.	Stud for fence plate	2
9.	Pointer bar	1
10.	Clamp plate	1
11.	Roller	1
12.	Clamp bar	1
13.	Guide collar	2
14.	Pointer	1
15.	Handwheel	2
16.	Bush	1
17.	Compression spring	1
18.	Kipp handle	1

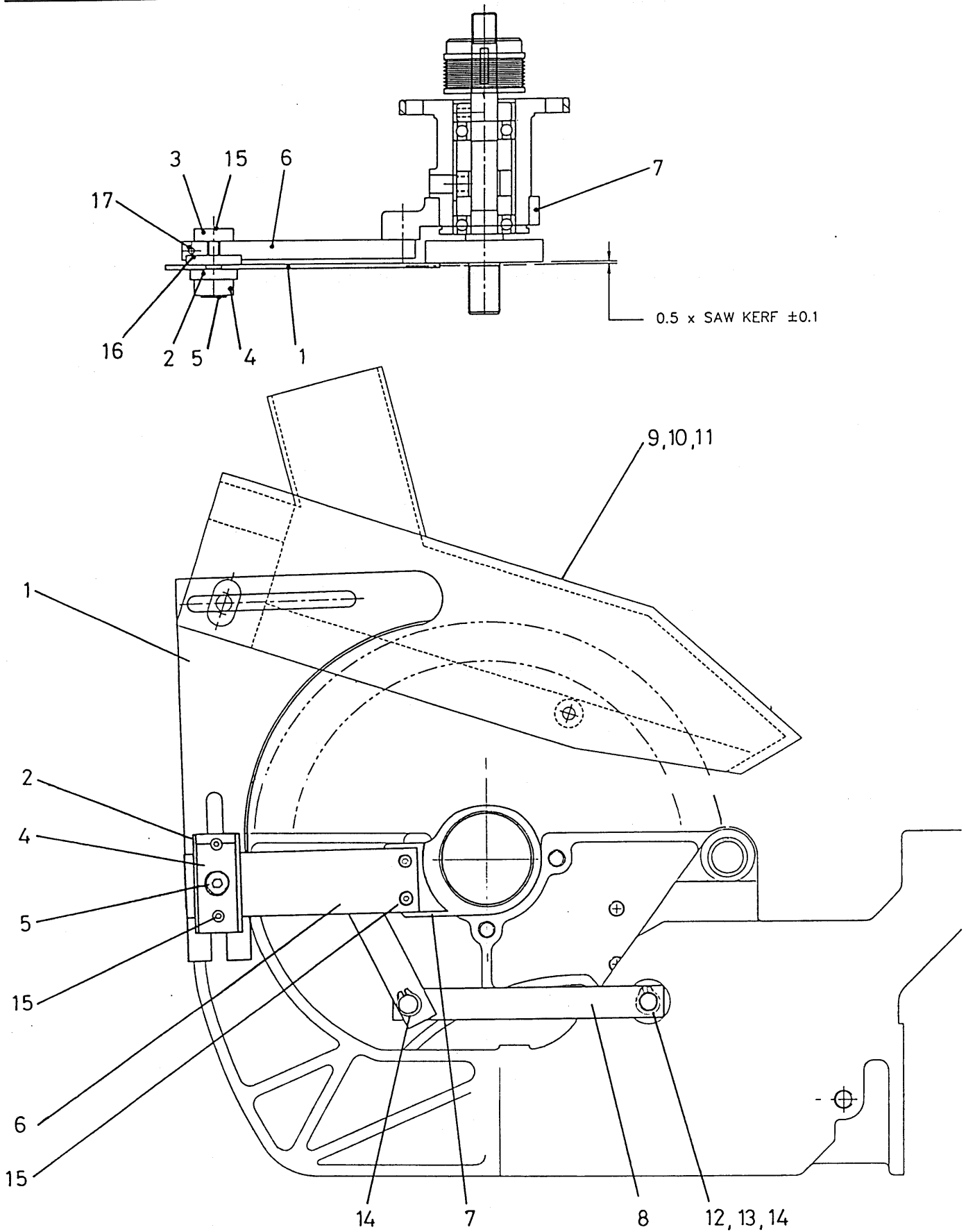

FIG 2 RIVING KNIFE ASSEMBLY

## 2. RIVING KNIFE ASSEMBLY

Ref No	Description	No Off
1.	Riving knife	1
2.	Pressure plate	1
3.	Rear clamp plate	1
4.	Front clamp plate	1
5.	Clamp screw	1
6.	Slide plate assembly	1
7.	Pivot bracket	1
8.	Rise and fall link plate	1
9.	Extraction adaptor (not illustrated)	1
10.	Extraction hood	1
11.	Extraction hood adjustable plate	1
12.	Link plate pivot pin	1
13.	Special locknut M12	1
14.	External circlip dia 12mm	2
15.	Hexagon socket capscrew M8 x 35mm long	4
16.	Riving knife guide plate	1
17.	Tension pin dia 4mm x 16mm long	1

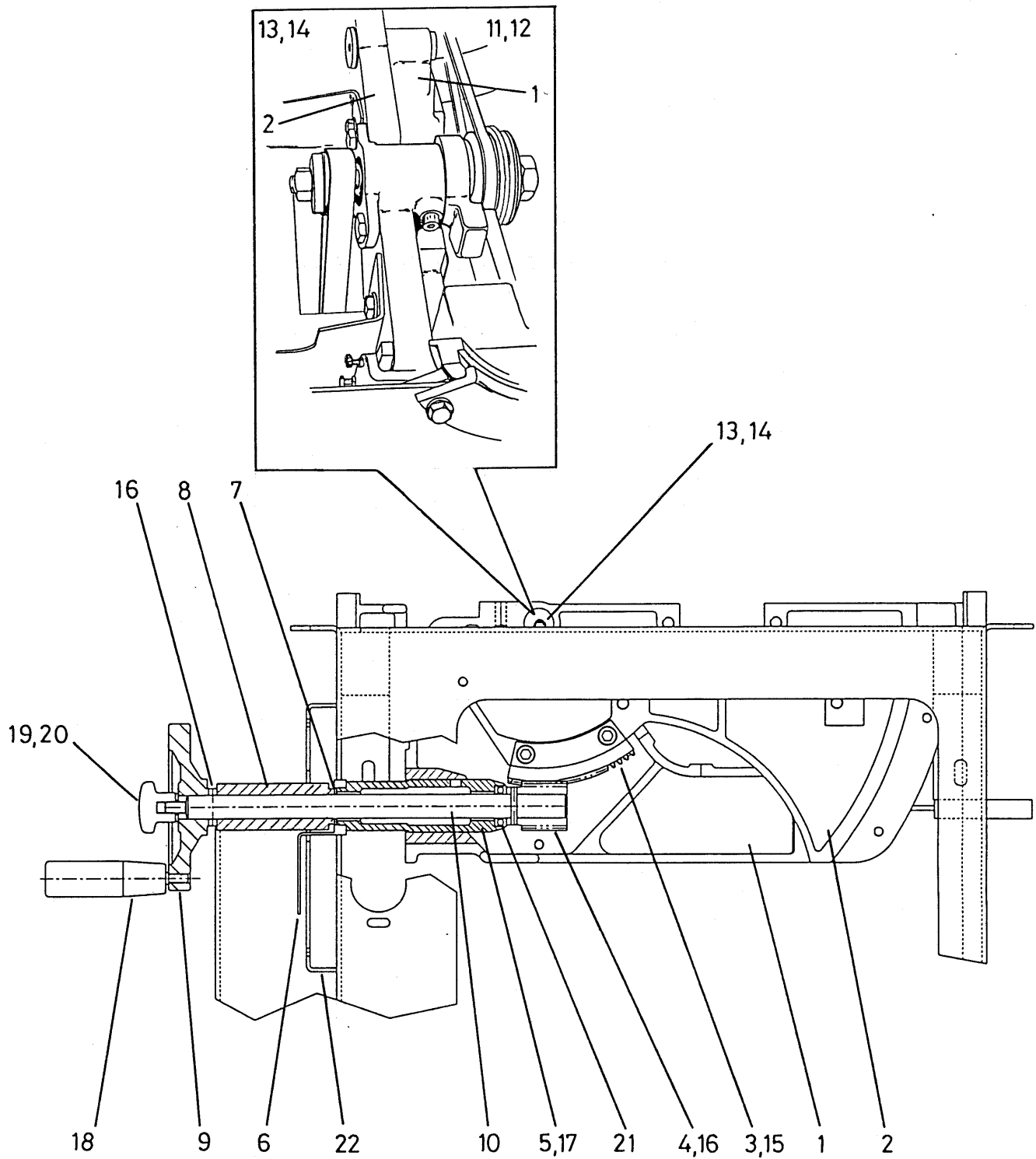

FIG 3 RISE AND FALL ASSEMBLY

### 3. RISE AND FALL ASSEMBLY

Ref No	Description	No Off
1.	Trunnion bracket	1
2.	Rise and fall slide	1
3.	Toothed gear quadrant	1
4.	Rise and fall worm gear	1
5.	Rise and fall shaft bearing housing	1
6.	Pointer assembly	1
7.	Brass washer	1
8.	Rise and fall shaft collar	1
9.	Hand wheel	1
10.	Rise and fall shaft	1
11.	Special washer 25mm O/D x 11mm I/D x 7mm thick	1
12.	Counter sunk hexagon socket screw M10 x 20mm long	1
13.	Rise and fall pivot	1
14.	Pre-load washer Ref EPL28	3
15.	Hexagon socket capscrew M10 x 25mm long	2
16.	Tension pin diameter 6mm x 30mm long	2
17.	Bronze bush 25mm O/D x 20mm I/D x 20mm long	2
18.	Handle	1
19.	Locking handle	1
20.	Plain washer M10	1
21.	'SKF' Thrust bearing ref 51104	1
22.	Control plate blank	1
23.	Screen printed control plate	1

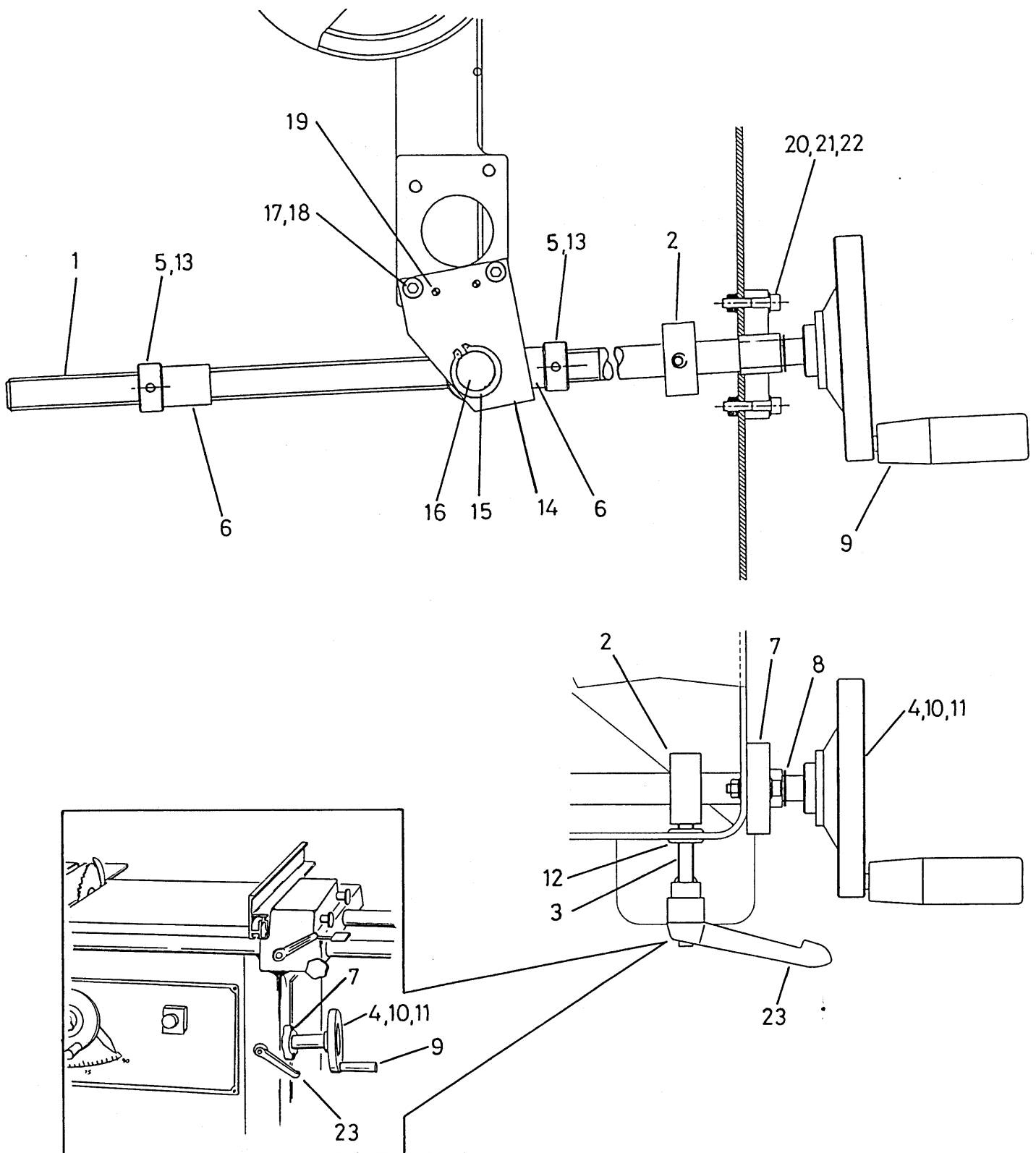

FIG 4 CANTING ADJUSTMENT

#### 4. CANTING ASSEMBLY

Ref No	Description	No Off
1.	Canting screw	1
2.	Canting lock bush	1
3.	Stud M10 x 90mm long	1
4.	Taper bush for handwheel	1
5.	Stop nut	2
6.	Stop collar	2
7.	'INA' Flanged bearing ref FLCTE 16	1
8.	External circlip diameter 16mm	1
9.	Handle	1
10.	Handwheel	1
11.	Hexagon socket countersunk screw M10 x 30mm long	1
12.	Rubber grommet 10mm	1
13.	Hexagon socket grub screw M6 x 6mm long	4
14.	Cant nut pivot plate	1
15.	Cant nut	1
16.	External circlip diameter 25mm	1
17.	Hexagon socket cap screw M8 x 20mm long	2
18.	Plain washer M8	2
19.	Tension pin diameter 6mm x 24mm long	2
20.	Hexagon socket capscrew M6 x 30mm long	2
21.	Plain washer M6	2
22.	Nut M6	2
23.	Kipp handle M10	1



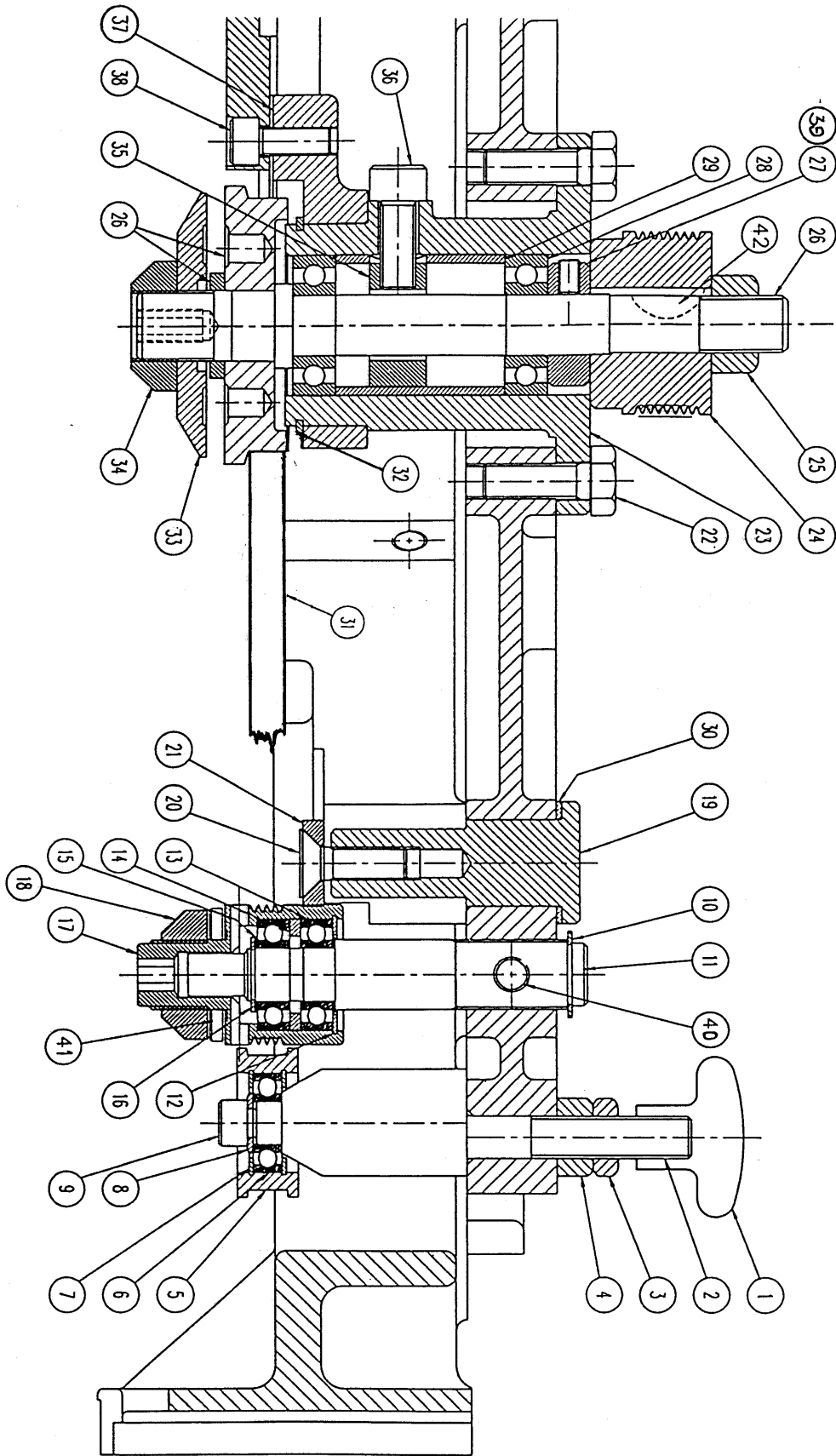

FIG 5 MAIN SAW SPINDLE AND SCORING SAW SPINDLE

## 5. MAIN SAW, SCORING SAW AND TENSIONER SPINDLES

Ref No	Description	No Off
1.	Handwheel	1
2.	Tension spindle	1
3.	M12 lock nut	1
4.	Nut M12	1
5.	Scoring saw tension spindle	1
6.	'RHP' Bearing ref 6001-2RS	1
7.	Internal circlip diameter 28mm	2
8.	Plain washer M8	1
9.	Hexagon socket caphead screw M8 x 12mm long	1
10.	External circlip diameter 18mm	1
11.	Scoring saw spindle	1
12.	Internal circlip diameter 32mm	1
13.	'RHP' bearing ref 6002-2RS	2
14.	Special washer 32mm O/D x 22mm I/D x 3mm thick	1
15.	Bump washer ref EPL12	1
16.	External circlip diameter 15mm	1
17.	Scoring saw pulley	1
18.	Scoring saw spindle nut	1
19.	Rise and fall pivot	1
20.	Hexagon socket countersunk screw M10 x 20mm long	1
21.	Special washer 25mm O/D x 11mm I/D x 7mm thick	1
22.	Hexagon head setscrew M10 x 30mm long	3
23.	Spindle housing	1
24.	Spindle pulley	1
25.	Nut M16	1
26.	Main spindle and back flange assembly	1
27.	Spindle locking collar	1
28.	'RHP' Bearing ref 6203-2RS	2
29.	Spindle distance piece	1
30.	Pre-load washer ref EPL28	4
31.	'Poly Vee' Scorer drive belt ref 260J4	1
32.	External circlip diameter 57mm	1
33.	Front saw flange	1
34.	Saw spindle nut	1
35.	Spindle trap collar	1
36.	Hexagon socket capscrew M10 x 25mm long	1
37.	Riving knife pivot bracket	1
38.	Hexagon socket capscrew M8 x 20mm long	2
39.	Hexagon socket grubscrew M6 x 10mm long	2
40.	Nylon grubscrew	1
41.	Scoring saw washer	1
42.	Woodruff key	1

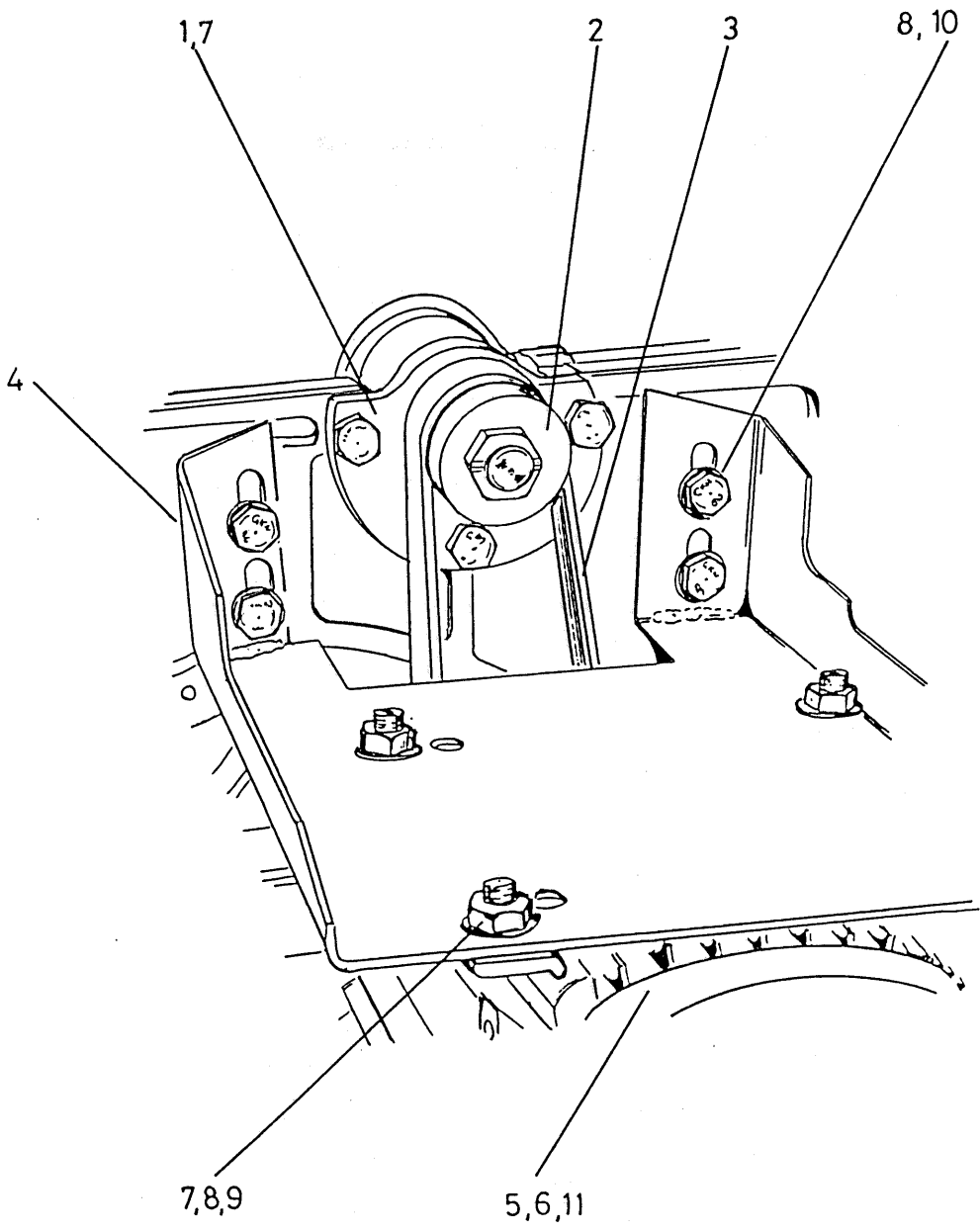

FIG 6 DRIVE MOTOR AND MOUNTING

## 6. DRIVE MOTOR AND MOUNTING

Ref No	Description	No Off
1.	Spindle housing	1
2.	Spindle pulley	1
3.	Poly 'v' belt Ref 220 J8	1
4.	Motor platform	1
5. *	Drive motor	1
6. *	Motor pulley	1
7.	Hexagon head setscrew M10 x 30mm long	7
8.	Plain washer M10	8
9.	Nut M10	4
10.	Hexagon head setscrew M10 x 25mm long	4
11.	Pulley key 7mm x 8mm x 32mm long (2.2 KW motor)	1
12.	Pulley key 7mm x 8mm x 40mm long (3.7 KW motor)	1

\* Specify drive motor size (if in doubt refer to specification plate fixed to drive motor casing)

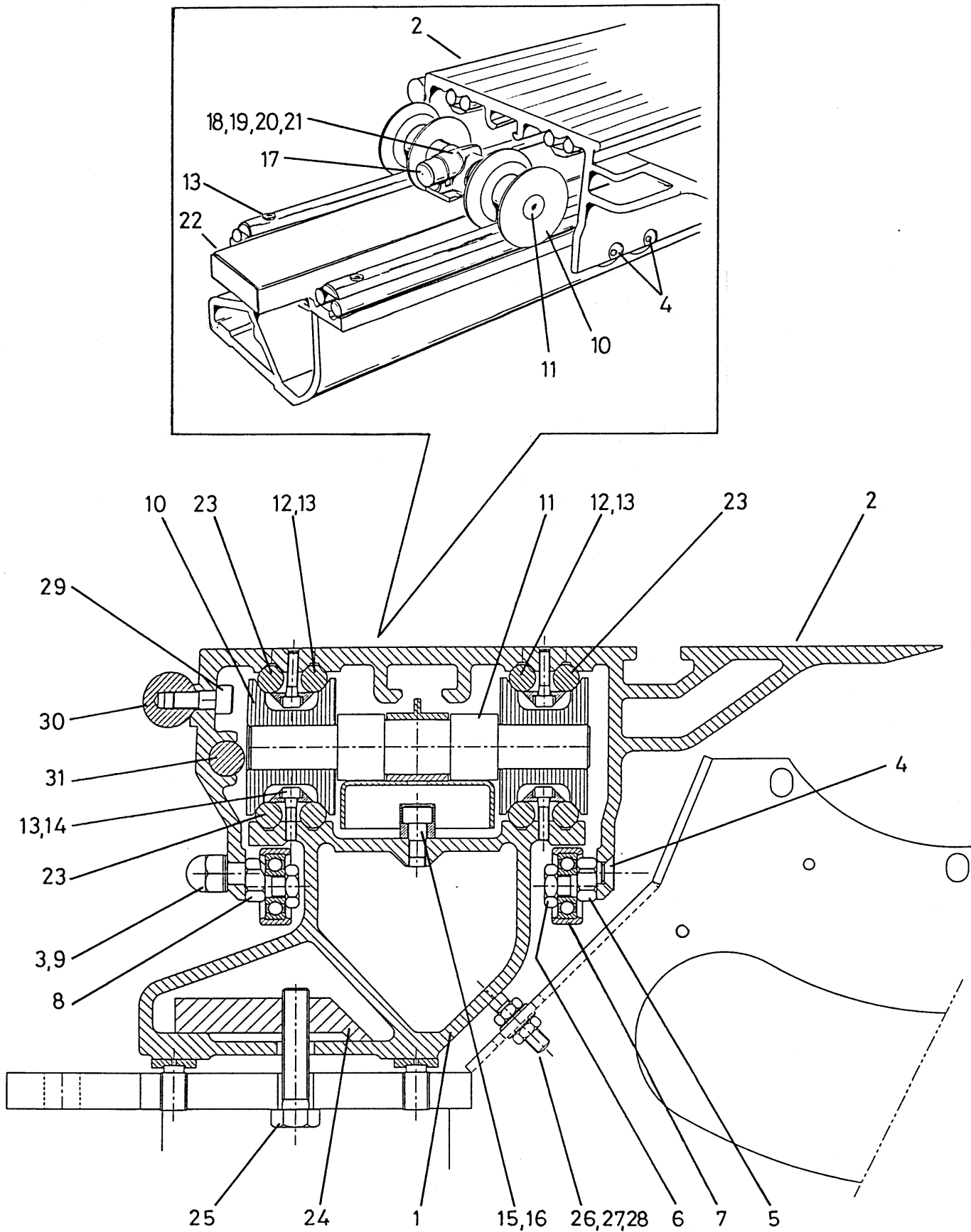

FIG 7 SLIDING TABLE

## 7. SLIDING TABLE

Ref. No	Description	No. Off
1.	Beam 3600mm long	1
2.	Sliding table (plain or anodised)	1
3.	Plain washer M10	6
4.	Hexagon socket countersunk screw M8 x 12mm long	4
5.	Roller eccentric	4
6.	Locknut M10	8
7.	Inner slide arm roller	8
8.	Eccentric pin under table roller	4
9.	Domed nut M10	4
10.	Diabolo roller	4
11.	Diabolo roller shaft	2
12.	Tapped inner slide table rod	2
13.	Hexagon socket capscrew M5 x 20mm long	54
14.	Slide rod clamp plate	4
15.	Hexagon socket capscrew M8 x 16mm long	2
16.	Stop for carriage	1
17.	Rubber stop	2
18.	Trapping bracket	2
19.	Self locking nut M8	2
20.	Trapping bracket spacer	2
21.	Socket button head screw M8 x 16mm long	4
22.	Carriage	1
23.	Sliding table rod	6
24.	Beam clamp plate	2
25.	Hexagon head setscrew M12 x 55mm long	2
26.	Stud M8 x 50mm long	2
27.	Locknut M8	2
28.	Plain washer M8	2
29.	Hexagon socket capscrew M8 x 25mm long	5
30.	Outrigger table support bar	1
31.	Table lock shaft	1

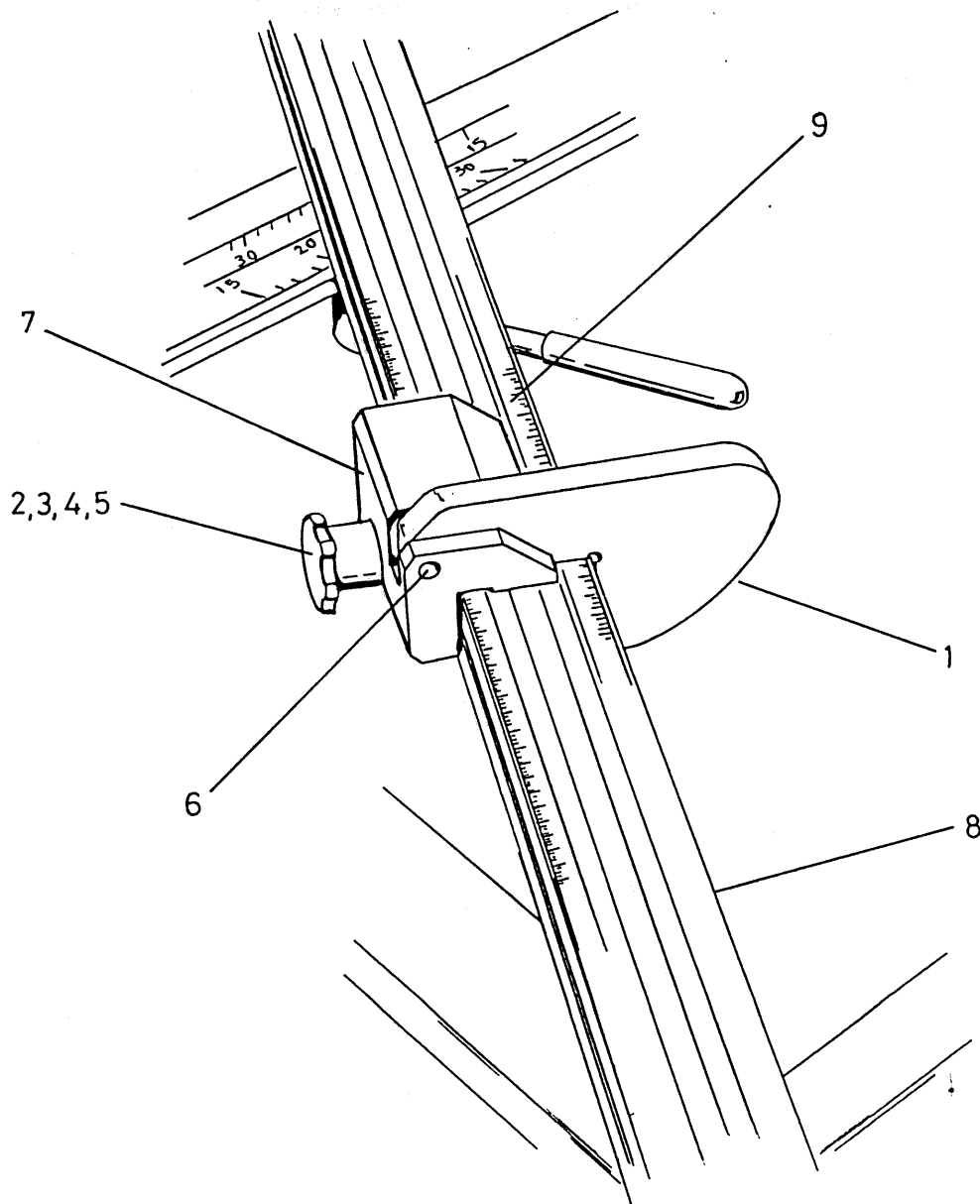

FIG 8 TURN-OVER STOPS

## 8. TURN-OVER STOPS

Ref No	Description	No Off
1.	Turn-over stop	1
2.	Hand wheel M8	1
3.	Stud M8 x 50mm long	1
4.	Plain washer M8	1
5.	Clamp shoe for turn-over stop block	1
6.	Retaining pin	1
7.	Turn-over stop block (right hand as illustrated or left hand)	1
8.	Crosscut fence (plain or anodised)	1
9.	Rule	2



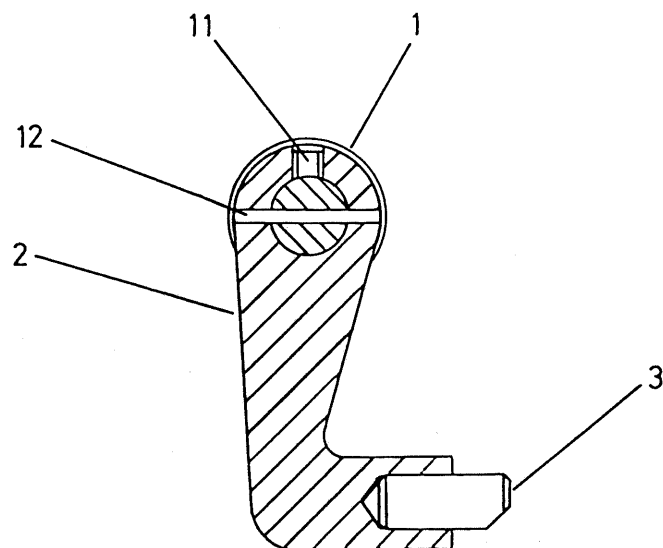
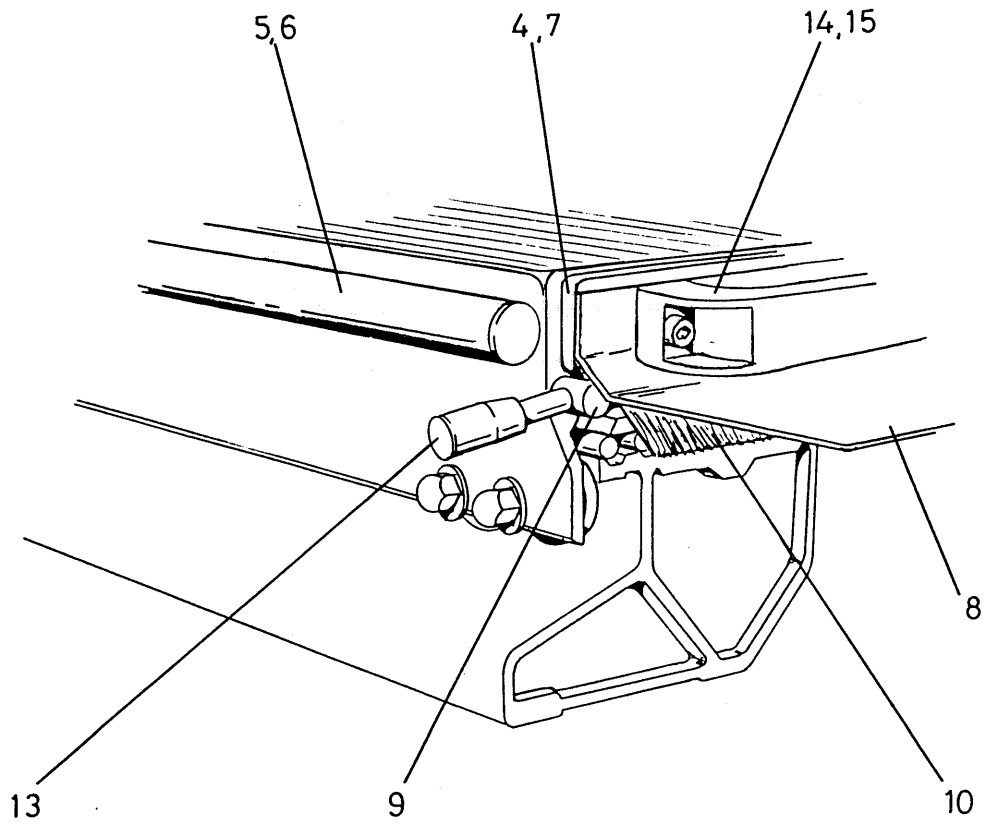

FIG 9 HANDLES AND LOCK FOR SLIDING TABLE

## 9. HANDLES AND LOCK FOR SLIDING TABLE

Ref No	Description	No Off
1.	Washer	1
2.	Stop bracket for sliding table	1
3.	Locating pin for table stop	1
4.	Hexagon socket capscrew M8 x 12mm long	4
5.	Hexagon socket capscrew M8 x 25mm long	5
6.	Support bar	1
7.	Table end plate (front)	1
	(rear)	1
8.	Table end cover (front)	1
	(rear)	1
9.	Table locking shaft	1
10.	Brush for sliding table	2
11.	Hexagon socket grubscrew M6 x 6mm long	1
12.	Tension pin dia 3mm x 24mm long	1
13.	Lever arm	1
14.	'Elesa' Handle Ref M443/150N	2
15.	Hexagon socket capscrew M6 x 12mm long	4
16.	Hexagon socket capscrew M8 x 12mm long	4

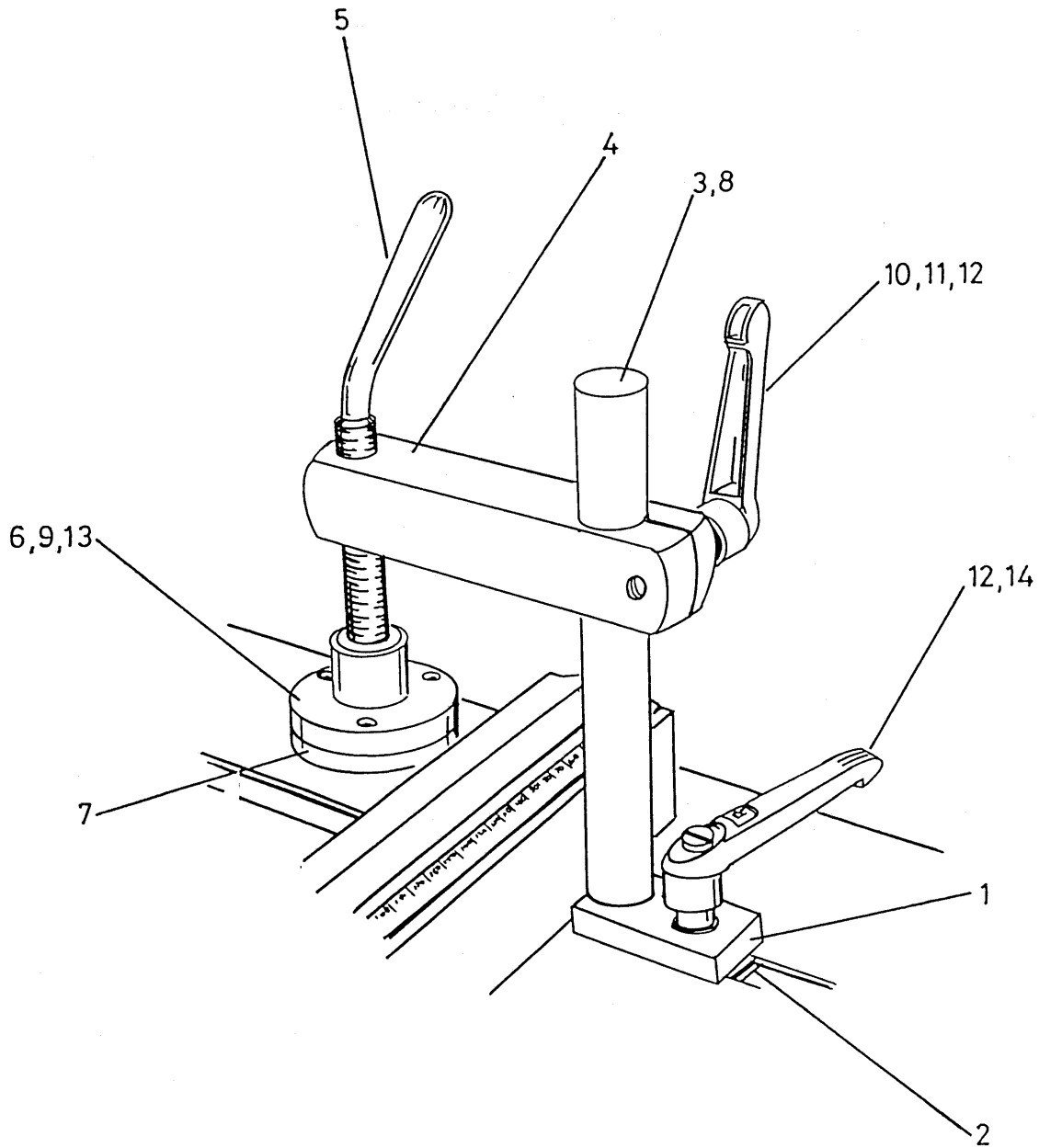

FIG 10 MANUAL CLAMP (OPTION)

## 10. MANUAL CLAMP

Ref No	Description	No. Off
1.	Clamp for key	1
2.	Key	1
3.	Pillar	1
4.	Clamp bar	1
5.	Clamp screw	1
6.	Clamp pad body	1
7.	Clamp pad	1
8.	Hexagon socket capscrew M10 x 40mm long	1
9.	Hexagon socket countersunk screw M6 x 20mm long	3
10.	Stud M10 x 40mm long	1
11.	Plain washer 10mm	1
12.	Kipp handle 10mm	2
13.	'O' Ring Ref RMO 146/24	1
14.	Stud M10 x 35mm long	1

# LIFTING AND TRANSPORTATION

## Dimensions and Weight

Length for transportation	1600mm
Width for transportation	1650mm
Height for transportation	1050mm
Gross Weight	520kg

## Unloading

Verify the lifting equipment used is capable of lifting the weight of the machine as a minimum.

The machine leaves the factory fitted to a wooden pallet or blocks which allows for lifting and movement by a forklift. Alternatively lifting slings may be positioned as illustrated. Whilst moving avoid jolting or vibrating the machine.

**WARNING:-** Never walk or stand under a raised machine.

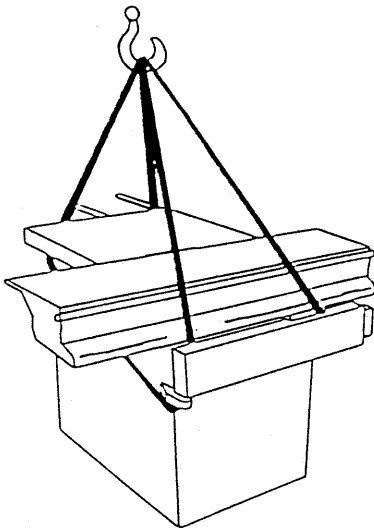

## Unpacking

The wooden transportation blocks secured to the base of the machine must be removed. To reduce the size of the machine for transport several items have been removed and individually packed. These items as well as the main body should be unwrapped and checked to make sure no damage has occurred in transit and to ascertain that the machine is complete with all fittings.

Check delivered items against the following list:-

**NOTE:-** Extras or customer special parts will not be listed and should be checked against order.

Outrigger table  
Turnover stops - 2 off  
Crosscut fence  
Main saw  
Scoring saw  
Saw guard  
Riving knives  
Rip fence guide bar  
Rip fence body  
Rip fence  
Rear extension table (optional)  
Legs for above - 2 off

*Tool kit comprising of:-*  
Push stick (C.E machines only)  
Instruction manual  
13mm A/F spanner  
32mm A/F spanner  
17/19mm A/F double ended spanner  
8mm long arm allen key  
6mm 'T' bar allen key  
5mm allen key  
4mm allen key



---

## IMPORTANT

### SAFETY PROCEDURES AND CONSIDERATIONS

To ensure safe working conditions, persons operating and assisting with the operation of this machine must ensure that they read and fully understand the instructions given within this manual and have received sufficient training in the use of the machine and the safety aspects to be observed.

**Note:-** Persons under the age of 18 years must not operate the machine except during the course of training under the supervision of a trained operator.

- A) POINTS TO NOTE BEFORE OPERATING OR ASSISTING WITH THE OPERATION OF THE MACHINE.**
- 1) You have read and understand the operation and safety aspects of the machine and have been checked out by a qualified supervisor.
  - 2) The machine is supplied with full safe guarding. The machine shall not be operated unless the safe guardings are in position and are functional.
  - 3) Cutters/blades are the correct type, suitable for the machine and working conditions, rotate in the correct direction of cut, are sharp and correctly fitted.
  - 4) Correct spindle and speeds are selected for the cutter equipment and working conditions.
  - 5) Loose clothing is either removed or securely fastened back and jewellery removed.
  - 6) Adequate working space and lighting is provided.
  - 7) All dust extraction equipment is switched on, properly adjusted and working adequately.
  - 8) The machine is securely installed (refer to installation section within this manual).
  - 9) The machine should only be used for cutting wood or materials with physical and technological characteristics similar to wood, and for which the chip or particle removal process is similar.
-

**B) DURING MACHINING:-**

- 1) Wear suitable protective clothing e.g, approved eye protection, ear defenders and dust masks. Gloves shall be worn when handling sharp edge saws.
- 2) Stop the machine using the emergency stop or at the mains isolator before making adjustments, cleaning or carrying out maintenance.
- 3) Keep the floor area around the machine clean and free from wood refuse. Do not allow the floor around the machine to become slippery.
- 4) Stop the machine and report immediately to a person in authority any actual or potential malfunction or operator hazard. Do not attempt to repair or rectify the machine unless qualified or authorised to do so.
- 5) The operator must not leave the machine running whilst unattended.
- 6) Never by-pass interlocks.
- 7) A push stick or handled push block must be used to feed the trailing edge of a workpiece past the cutting blade.
- 8) When ripping never stand directly behind the material.

**WARNING:-**

Failure to observe correct operating procedures prior to and during operation of this machine can result in severe injury.

**DO NOT** attempt to operate the machine while under the influence of anything that reduces your alertness.

---

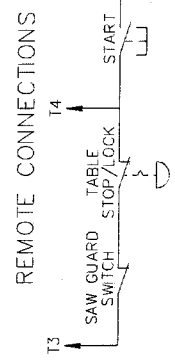
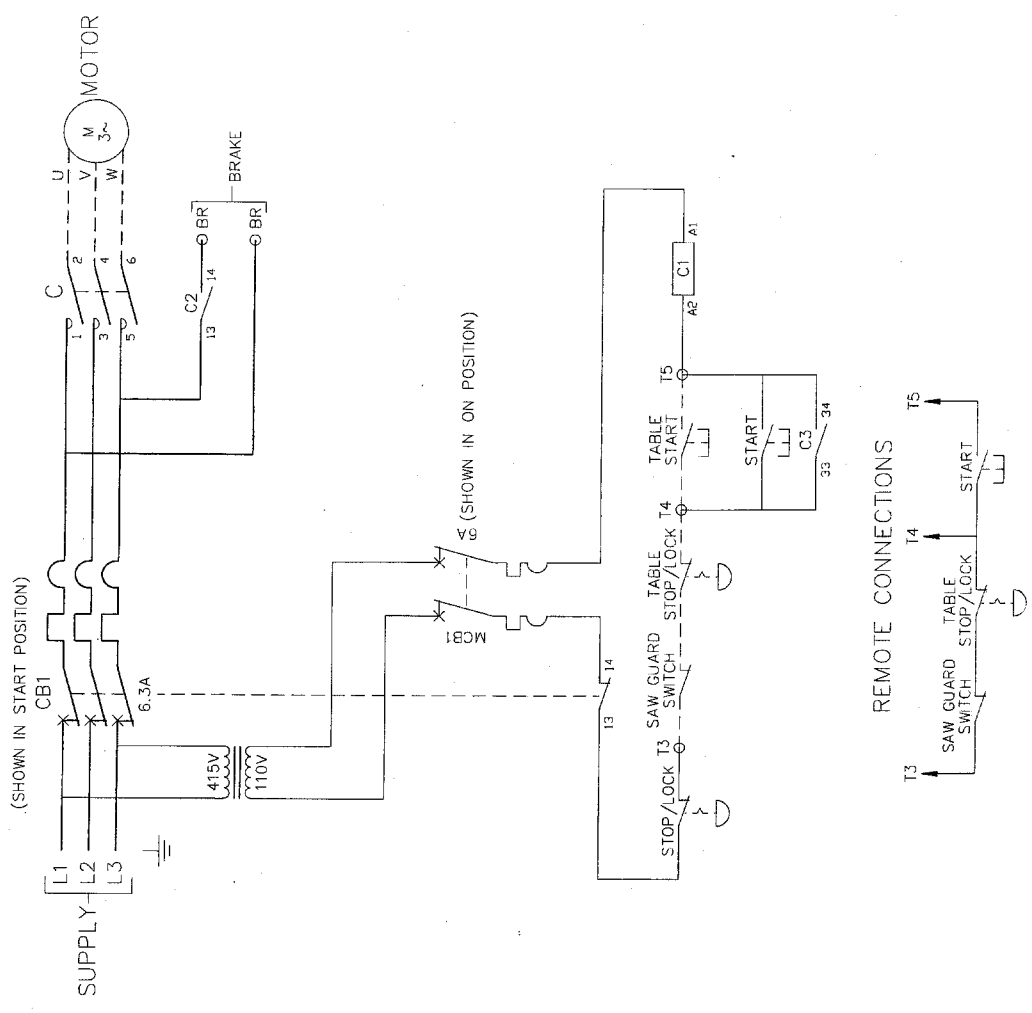
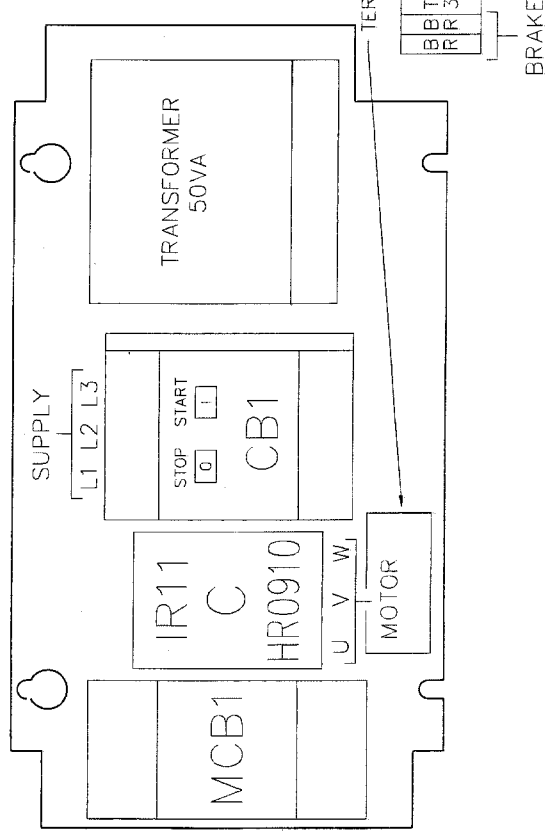
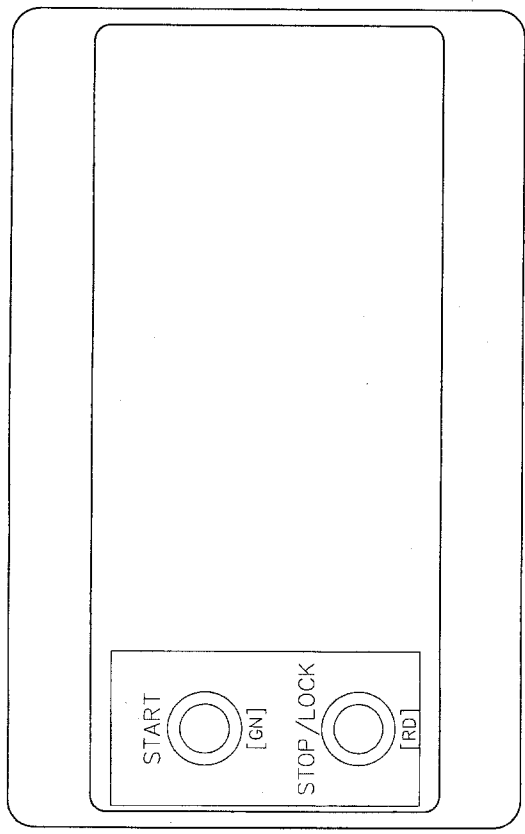

ISO 9001, QUALITY IS YOUR RESPONSIBILITY, IF IN DOUBT ASK.

MATERIAL		RECORDED ISSUE No.	
FINISH		DRN <i>D.Gaines</i>	CKD
TITLE		DATE 14.5.98	SCALE
CURRENT REVISION No		DRAWING NUMBER	
All mains wiring BLACK All a.c. control wiring RED All d.c. control wiring BLUE As EN60204 Part 1 Unless otherwise stated		A3/K20318/LK	
C.D. FOR SPECIAL CONTROLLER C.D. FOR SPECIAL CONTROLLER		Brook Crompton Controls Monckton Road, Wakefield West Yorkshire WF2 7AL Tel: (01924) 368251 Fax: (01924) 357274	
ALT CKD DATE		BROOK CROMPTON 	



# *Wadkin*

**ULTRACARE LTD.**  
spares +44 (0)870 850 9114  
tooling +44 (0)870 850 9113  
service +44 (0)870 850 9112