

INSTRUCTION MANUAL & PARTS LIST

FOR PANEL SIZING AND DIMENSION

SAWS

**CP12 & CP12/D**

IMPORTANT

It is our policy and that of our suppliers to review constantly the design and capacity of our products. With this in mind we would remind our customers that whilst the dimensions and performance data contained herein are current at the time of going to press, it is possible that, due to the incorporation of latest developments to enhance performance, dimensions and supplies, may vary from those illustrated.

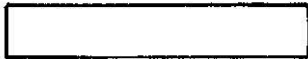

PLEASE INSERT SERIAL NUMBER OF MACHINE

# Instruction Manual For

# CP12 & CP12/D

## Panel Sizing and Dimension Saws

HEALTH & SAFETY	Page 2 & 3
SPECIFICATION	Page 6
STANDARD ITEMS DESPATCHED	Page 7 & 8
SLINGING	Page 13
CLEANING	Page 13
FOUNDATION	Page 9, 10 & 13
WIRING DETAILS	Page 11, 12 & 13
LUBRICATION	Page 13 & 28
ASSEMBLY OF MACHINE	Page 15
GUARD & RIVING KNIFE ADJUSTMENTS	Page 17
TURNOVER STOPS	Page 17
POSITIONING OF SLIDING TABLE CARRIAGE	Page 17
SLIDING TABLE LOCK	Page 17
MAIN START STOP	Page 17
SCORING SAW	Page 17
ISOLATOR SWITCH	Page 17
EXHAUST OUTLET	Page 17
RISE & FALL CONTROLS	Page 18
CANTING CONTROLS	Page 18
RIP FENCE	Page 19
MOUNTING MAIN SAWBLADE	Page 21
MOUNTING SCORING SAWBLADE	Page 21
SETTING SAW TO RIVING KNIFE	Page 23
SCORING SAW	Page 23
SCORING SAW ALIGNMENT	Page 23
GENERAL MAINTENANCE	Page 25
SAW SPINDLE SPEED CHANGING OR BELT CHANGING	Page 25
BELT CHANGING ON SCORING SAW	Page 25
SAFETY	Page 27
SAWBLADES	Page 27
BELTS & BEARINGS	Page 27
MACHINE PARTS LIST	Page 30 to 49

FOR REPLACEMENT PARTS, TOOLS AND ACCESSORIES, CONTACT:-

(0116)276 9111

Bursgreen (Durham), Division of Wadkin PLC, Fence Houses, Houghton le Spring,  
Tyne & Wear, England, DH4 5RQ.



## HEALTH & SAFETY

### SAFETY OF WOODWORKING MACHINES

Woodworking machines can be dangerous if improperly used. The wide range of work of which they are capable, requires adequate safeguarding arrangements against possible hazards.

Many injuries to machinists are caused by carelessness or failure to use the guards provided or to adjust them correctly.

WADKIN LTD., supply machinery designed for maximum safety which they believe, as a result of thorough testing, minimizes the risks inevitable in their use. It is the user's responsibility to see that the following rules are complied with to ensure safety at work:

1. The operation of the machine should conform to the requirements of the Woodworking Machines Regulations 1974. All guards should be used and adjusted correctly.
2. Safe methods of working only should be adopted as given in the Health and Safety Work Booklet No.41, "Safety in the Use of Woodworking Machines", (obtainable from Her Majesty's Stationery Office) and as advised by Wadkin Ltd.
3. Only personnel trained in the safe use of a machine should operate it.
4. Before making adjustments or clearing chips, etc., the machine should be stopped and all movement should have ceased.
5. All tools and cutters must be securely fixed and the speed selected must be appropriate for the tooling.

*SAFETY IS OUR WATCHWORD BUT THE USER MUST COMPLY WITH THE ABOVE RULES IN HIS OWN INTEREST. WE WOULD BE PLEASED TO ADVISE ON THE SAFE USE OF OUR PRODUCTS.*

## Safety

CAREFULLY READ INSTRUCTION MANUAL WITH PARTICULAR REFERENCE TO THE FOLLOWING INSTRUCTIONS:-

1. SLINGING, i.e. SAFE LIFTING LIMITS FOR SLINGS ETC.
2. INSTALLATION AND FOUNDATION, i.e. SAFE WORKING AREA OF MACHINE AND BOLT POSITIONS; ETC.
3. WIRING DETAILS, i.e. WIRING DIAGRAM AND INSTRUCTIONS FOR SAFE WIRING OF MACHINE.
4. MACHINE CONTROLS AND OPERATING INSTRUCTIONS.
5. SELECT CORRECT SPEED FOR CUTTER EQUIPMENT AND ENSURE CUTTERS ARE SECURELY LOCKED IN POSITION.
6. SET GUARDS CORRECTLY TO COVER CUTTER EQUIPMENT AS MUCH AS POSSIBLE.
7. NOTE START/STOP CONTROL POSITION AND ISOLATOR SWITCH POSITION (IF FITTED) BEFORE OPERATING MACHINE.
8. USE FEEDING DEVICES WHERE POSSIBLE.
9. REFER TO HEALTH AND SAFETY AT WORK BOOKLET No.41 (IN U.K.) FOR SAFETY IN THE USE OF WOODWORKING MACHINERY.
10. DO NOT RUN LARGE SAWBLADES AT HIGH SPEED.

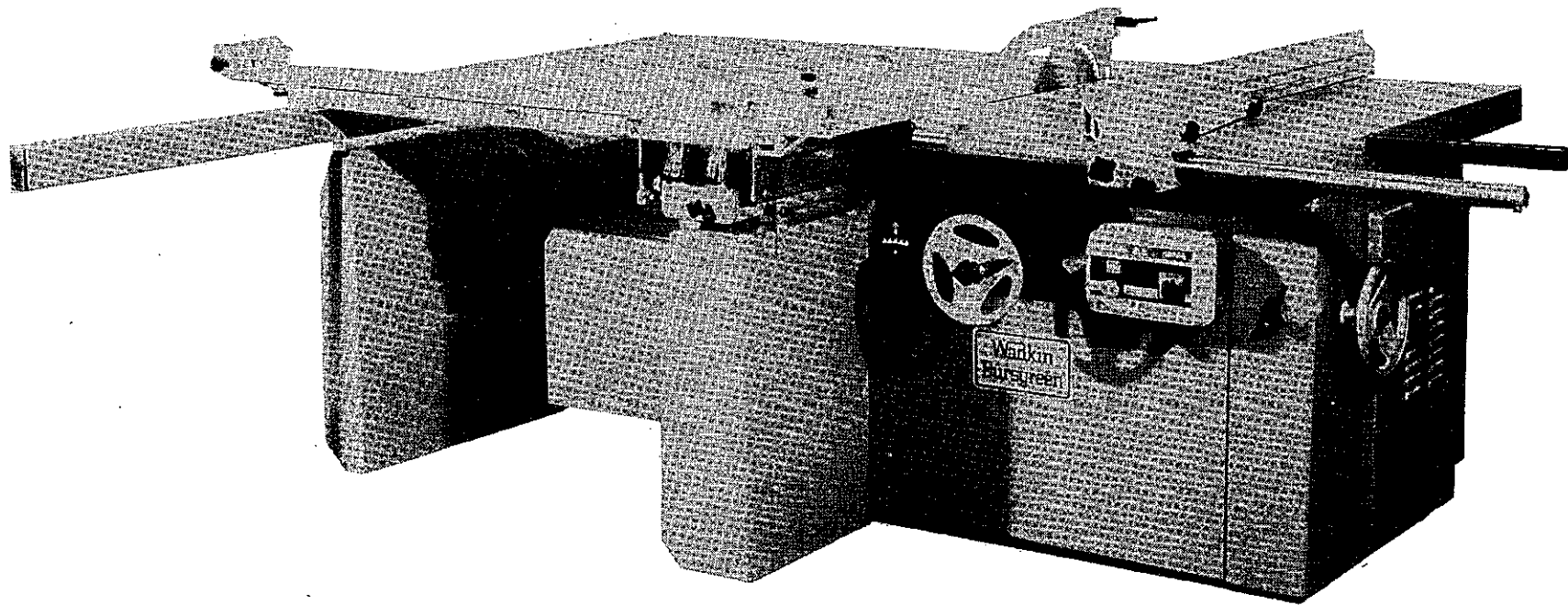

PANEL SAW CP12

FIG. 1

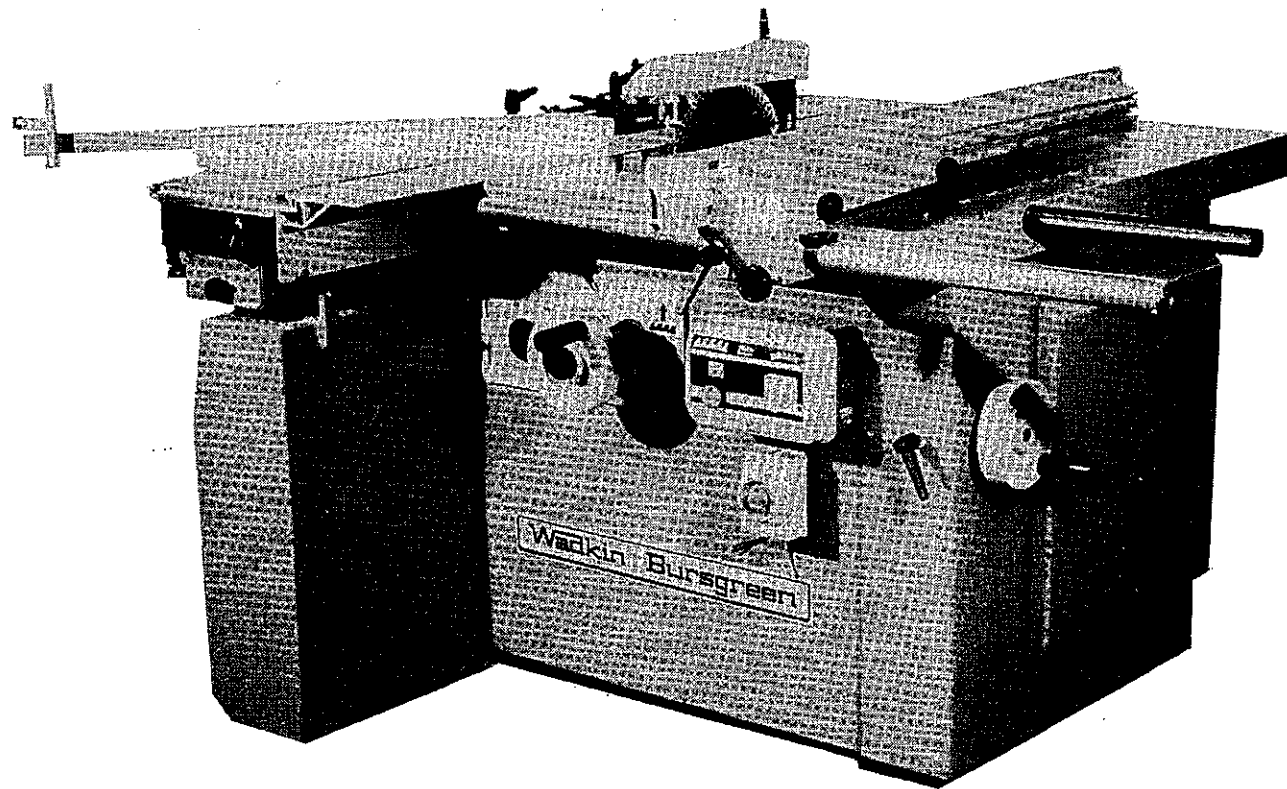

DIMENSION SAW CP12/D

FIG. 2

SPECIFICATIONCP12CP12/D

Size of Main Table	744mm x 1067mm	29 x 42in	744mm x 1067mm	29 x 42in
Size of Sliding Table	1350mm x 1300mm	53 x 51in	400mm x 1300mm	15½ x 51in
Length of Cut with Sliding Table	1250mm	49in	1250mm	49in
Height of Table	850mm	33½in	850mm	33½in
Max. Distance Saw to Stop on Crosscut Fence	2500mm	98in		
Max. Distance Saw to Stop on Mitre Fence			1250mm	49in
Max. Distance Saw to Rip Fence	920mm	36in	920mm	36in
Max. Distance Saw to Rip Fence with Extension Table	1255mm	49in	1255mm	49in
Saw Projection at 90° with 400mm Blade	50 to 135mm	2 to 5.3/8in	50 to 135mm	2 to 5.3/8in
Saw Projection at 45° with 400mm Blade	95mm	3¾in	95mm	3¾in
Saw Projection at 90° with 300mm Blade	0 to 80mm	0 to 3.1/8in	0 to 80mm	0 to 3.1/8
Max. Dia of Saw	400mm	15¾in	400mm	15¾in
Min. Dia of Saw	250mm	10in	250mm	10in
Power of Main Motor - Standard	4kw	5.5hp	4kw	5.5hp
- Optional	5.5kw	7.5hp	5.5kw	7.5hp
	7.5kw	10hp	7.5kw	10hp
Spindle Speeds	2800, 3800, 4500 RPM	2800, 3800, 4500 RPM	2800, 3800, 4500 RPM	2800, 3800, 4500 RPM
Spindle Dia	30mm		30mm	
Dia of Scoring Saw	105mm	4in	105mm	4in
Power of Scoring Motor	0.5kw	0.75hp	0.5kw	0.75hp
Scoring Saw Spindle Speed	8500rpm		8500rpm	
Max. Dia of Saw when Scoring	300mm		300mm	
Approx. Floor Space	2820 x 3690mm	111 x 145in	2820 x 1540mm	111 x 61in
Approx. Net Weight	530kgs		505kgs	
Approx. Gross Weight	570kgs		545kgs	
Shipping Dimensions of Machine	1.59 x 1.435 x 1.16m	59 x 56½ x 45½in	1.44 x 1.30 x 0.98m	56½ x 51 x 38½in
Shipping Dimensions of Outer Support	2.45 x 0.15 x 0.10m	96½ x 6 x 4in		

STANDARD ITEMS DESPATCHED WITH MACHINE

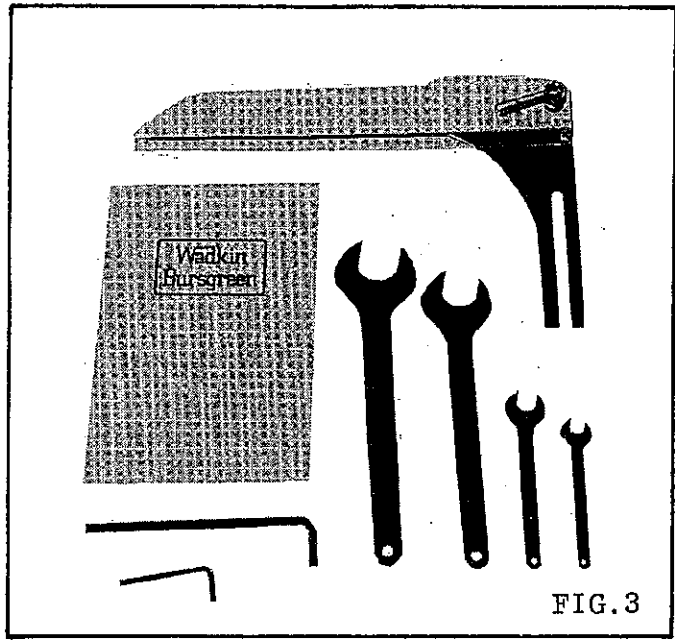

FIG.3

- 1 - Instruction Manual
- 1 - Riving Knife P32/353
- 1 - Sawguard 1041/144
- 1 - Sawguard Locking Bolt Complete
- 1 - 36mm A/F Spanner
- 1 - 32mm A/F Spanner
- 1 - 17mm A/F Spanner
- 1 - 13mm A/F Spanner
- 1 - 8mm Long Arm Hexagon Wrench
- 1 - 5mm Hexagon Wrench

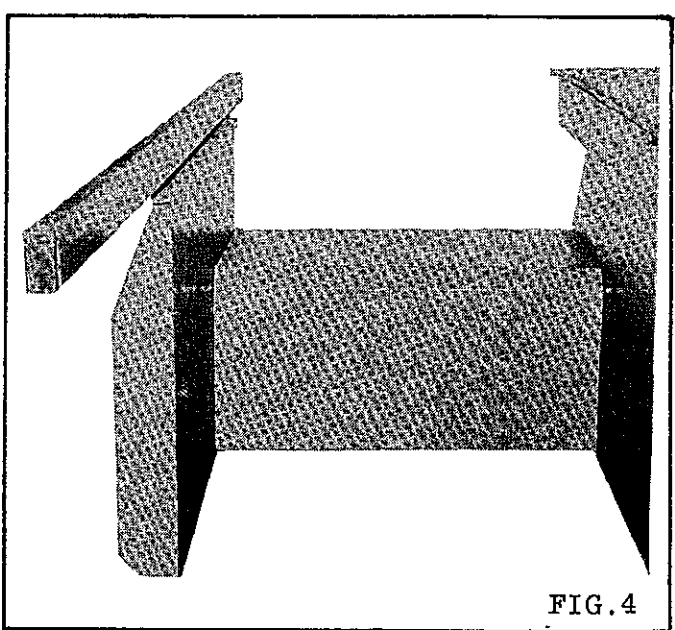

FIG.4 - CP12 only

- 1 - Outer Support Rail
- 1 - Tie Piece

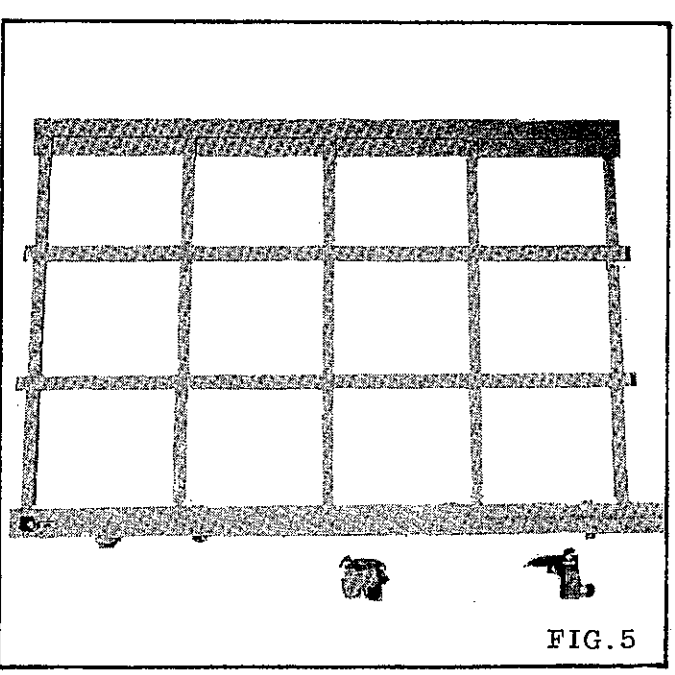
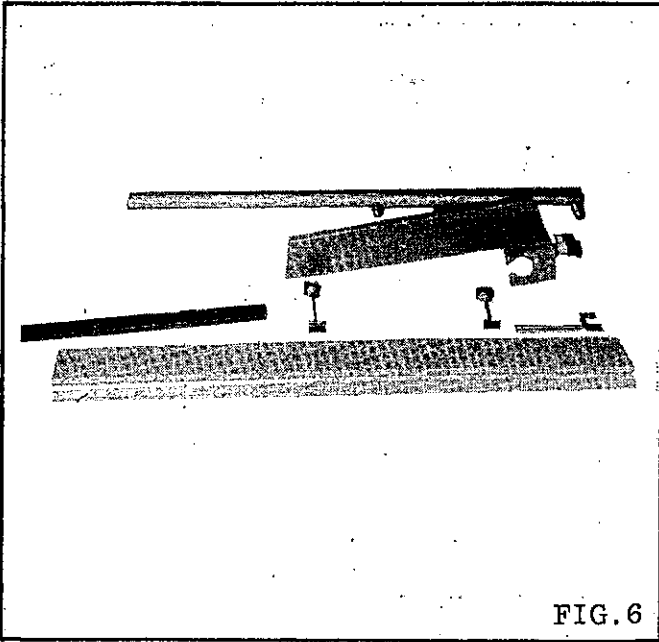

FIG.5 - CP12 only

- 1 - Outrigger Table c/w Crosscut Fence
- 2 - Turnover Stops c/w Locking Shoes

FIG.5





STANDARD ITEMS DESPATCHED  
WITH MACHINE CONTINUED

FIG.6

- 1 - Fence Bar
  - 1 - Rip Fence Bracket
  - 1 - Rip Fence Plate
  - 2 - Rip Fence Plate Locking  
Bolts c/w Plastic Handwheels
  - 1 - Rip Fence Pointer
  - 1 - Rip Fence Support Bar..
- Not supplied when extension  
table is fitted.

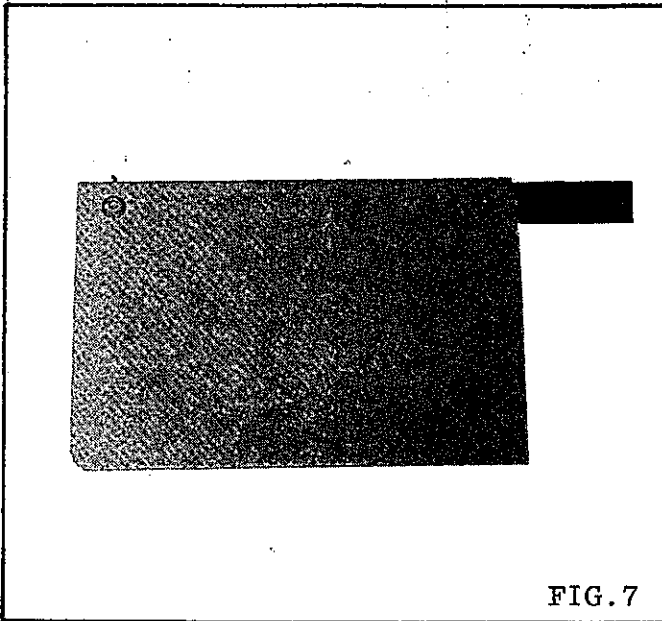
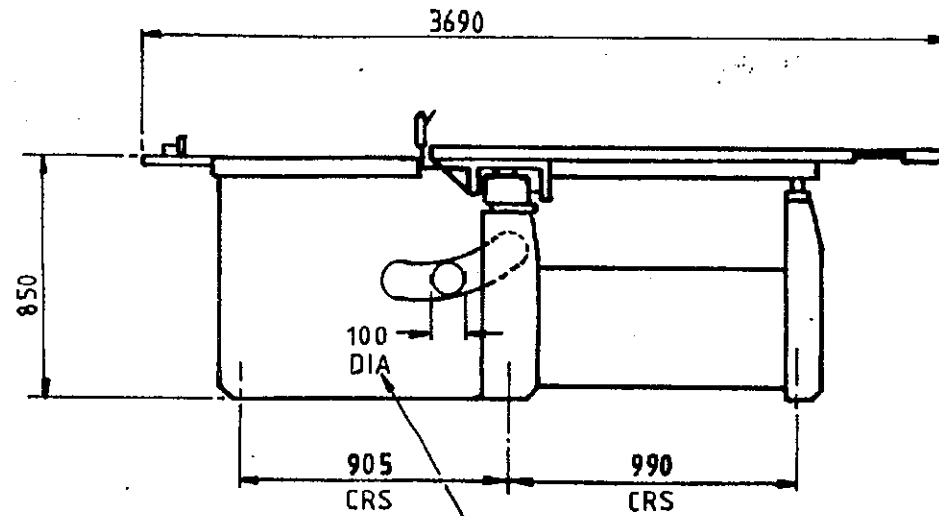
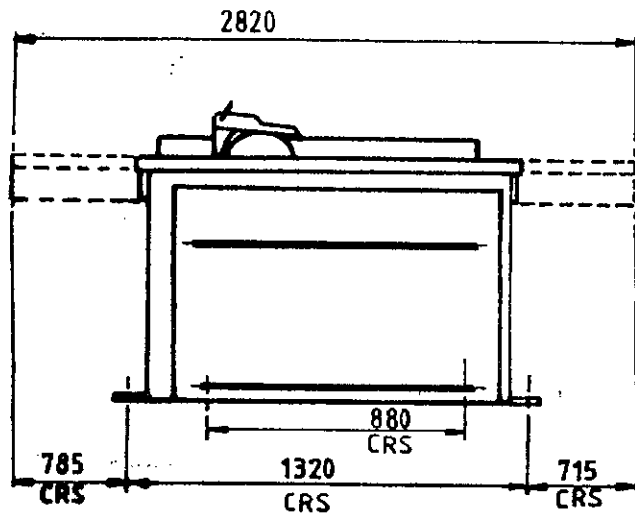

FIG.7

- 2 - Sliding Table Guards

HOME ORDERS ONLY



DUST OUTLET (VOLUME OF AIR TO BE EXTRACTED = 375 C.F.M.)

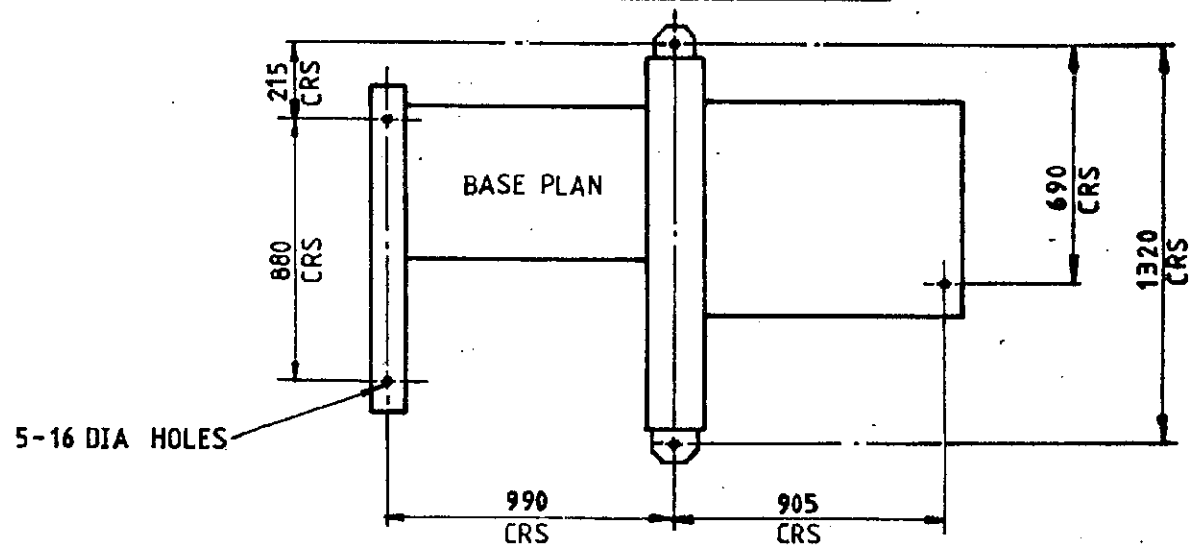
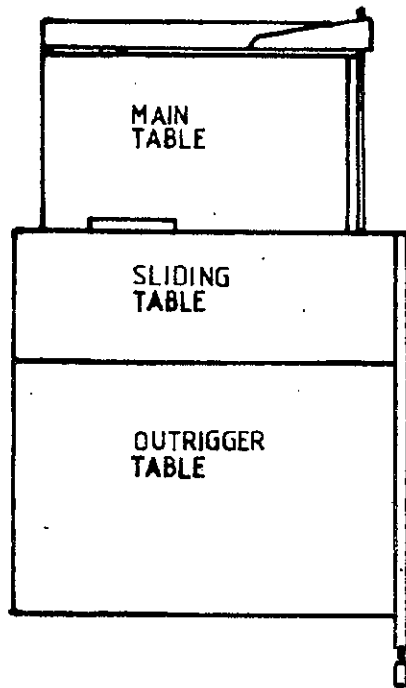

FOUNDATION PLAN FOR CP12

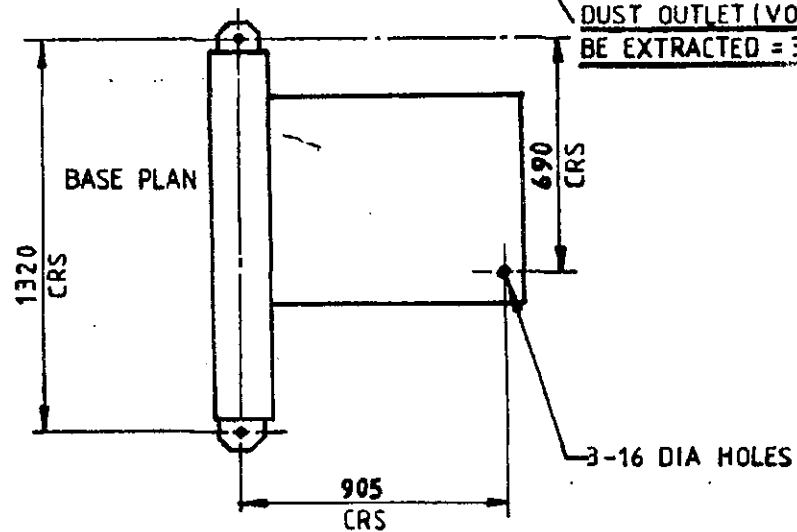
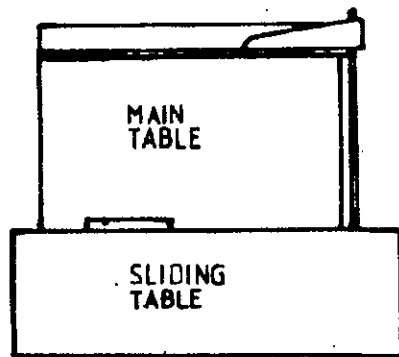
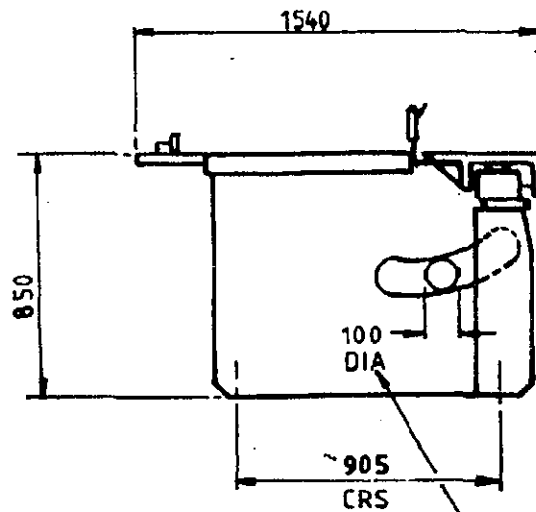
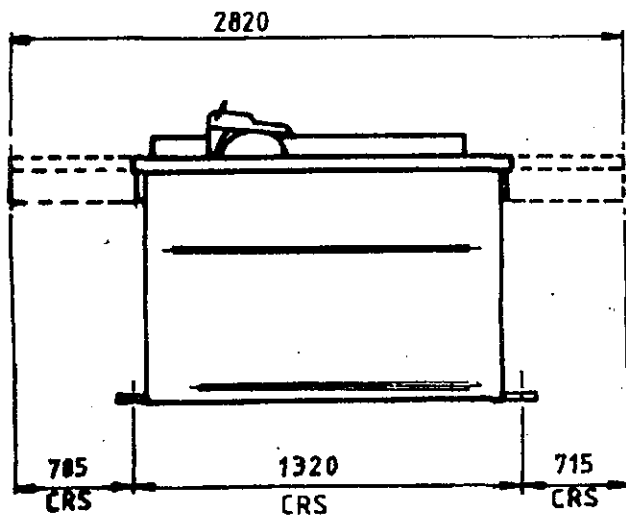

FOUNDATION PLAN FOR CP12/D

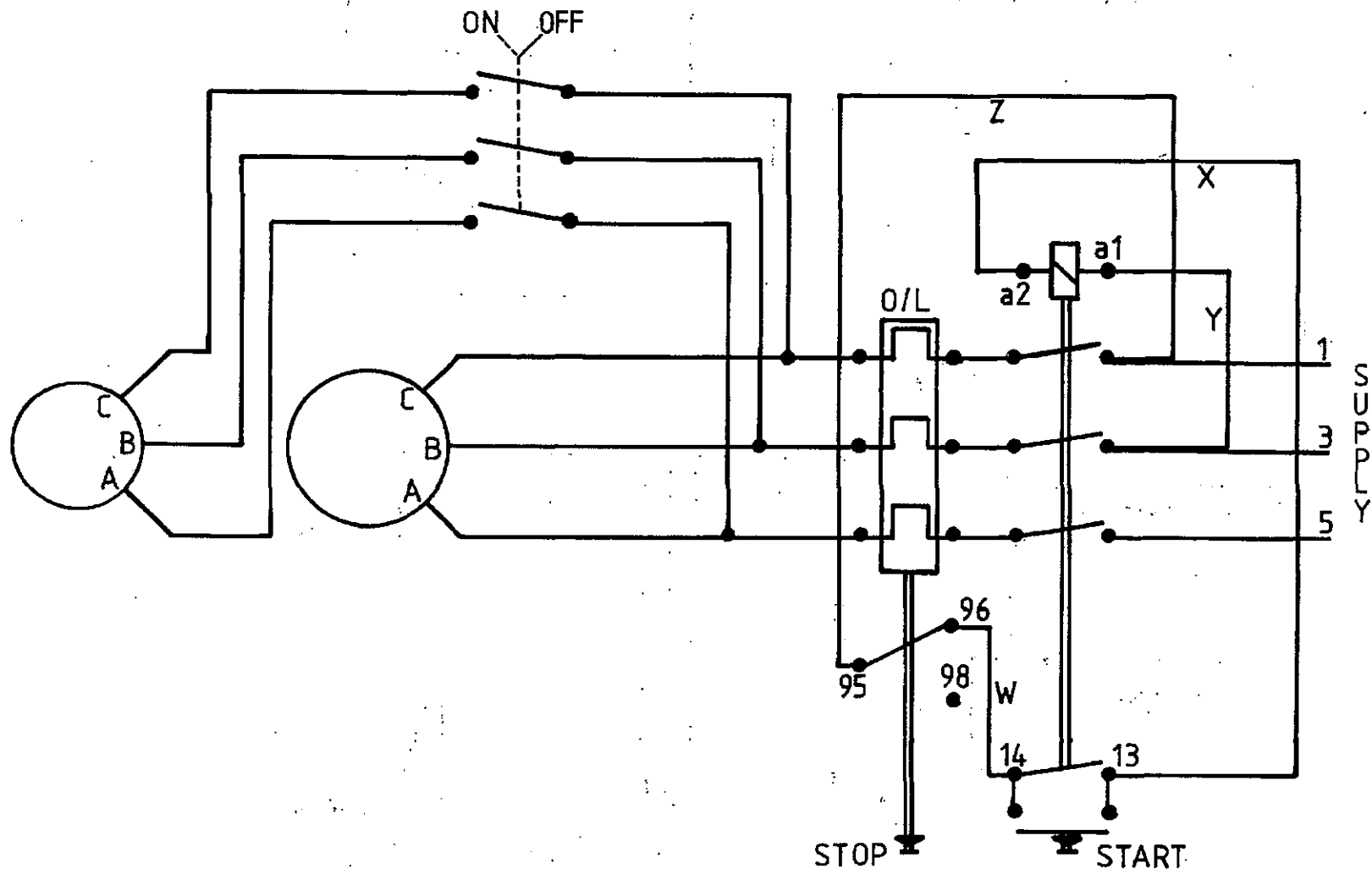

WIRING DIAGRAM  
DIRECT ON LINE STARTER

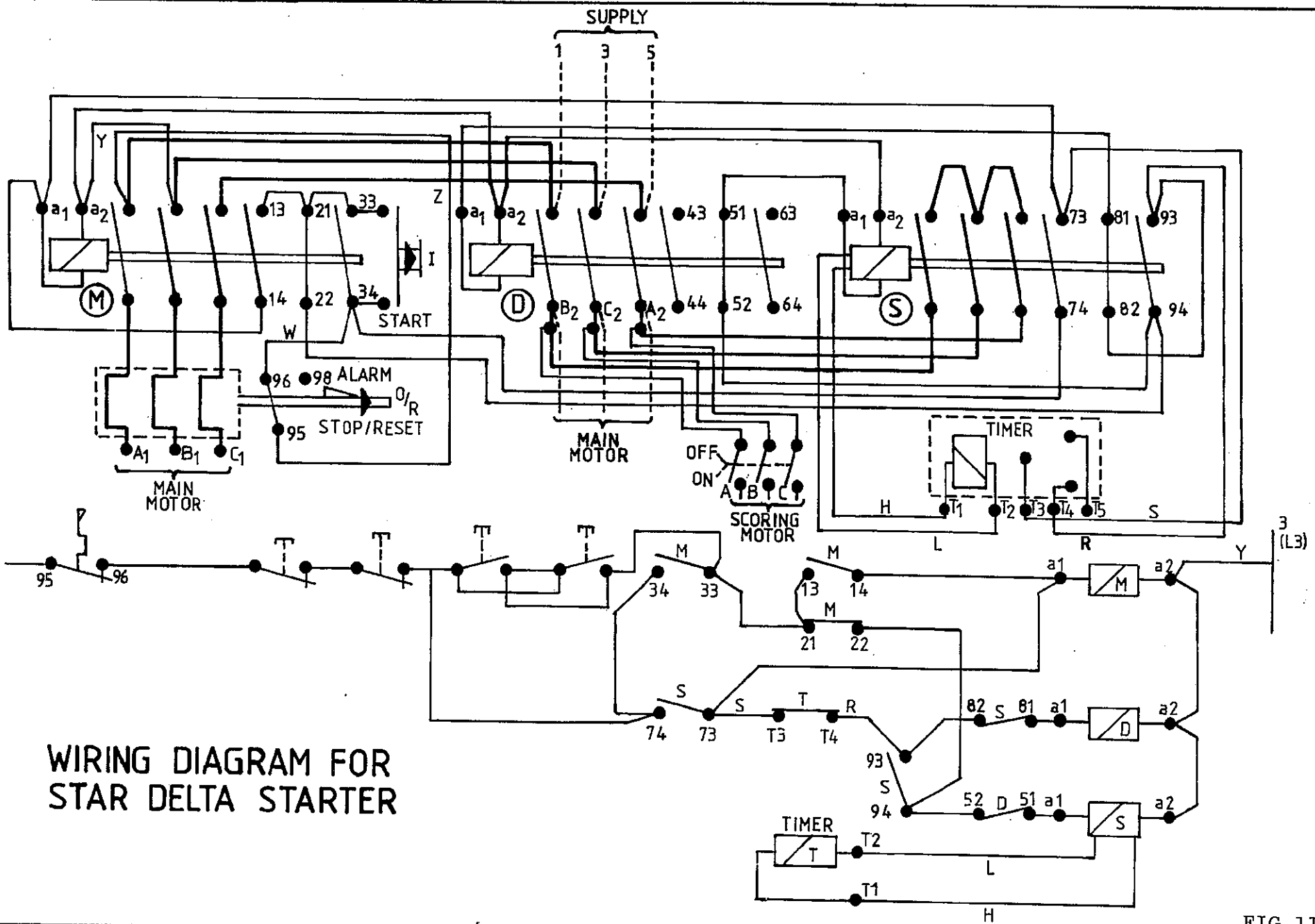

WIRING DIAGRAM FOR  
STAR DELTA STARTER

FIG. 11

SLINGING

Always use a sling within safe working load of machine weight.

CP12 - Approximate net weight of machine	530 kgs
CP12 - Approximate gross weight of machine	570 kgs
CP12/D - Approximate net weight of machine	505 kgs
CP12/D - Approximate gross weight of machine	545 kgs

Attach slings to machine as shown in FIG.12, ensuring damage will not be caused to machine during slinging operation.

**IMPORTANT: DO NOT WALK OR STAND UNDER MACHINE DURING SLINGING OPERATION.**

CLEANING

Clean protective coating from all bright parts by applying a cloth soaked in paraffin, turpentine or other solvent.

FOUNDATION

The machine is front loading and should be sited to allow working room for all capacities. Refer to foundation plan FIG.8 for CP12 and FIG.9 for CP12/D. Ensure floor is level, then mark floor to suit 5-M12 rawlbolts for CP12 and 3-M12 rawlbolts for CP12/D. Drill floor to suit rawlbolts. These bolts are not supplied with the machine, but can be supplied at an additional charge.

WIRING DETAILS

The motor and control gear have been wired in before despatch. All that is required is to connect the power supply to the isolating switch.

Points to note when connecting power supply:-

- 1 Check the voltage, phase and frequency correspond to those on the motor plate, also the correct coils and heaters are fitted to the starter.
- 2 It is important that the correct cable is used to give the correct voltage to the starter as running on a low voltage will damage the motor.
- 3 Check the main fuses are of the correct capacity. See fuse list inside starter cover or isolator if fitted.
- 4 Connect line leads to the appropriate terminals. See wiring diagrams, FIG.10 or FIG.11.
- 5 Check all connections are sound.
- 6 Check the rotation of both motors for correct direction. If these are incorrect, reverse any two of the line lead connectors.

LUBRICATION

All bearings are sealed for life and require no lubrication. Oil Rise/Fall screw, canting screw and slides - once weekly. Approved lubricants, see page 28.

It is advisable to keep all bright parts covered with a thin film of oil to prevent rusting.

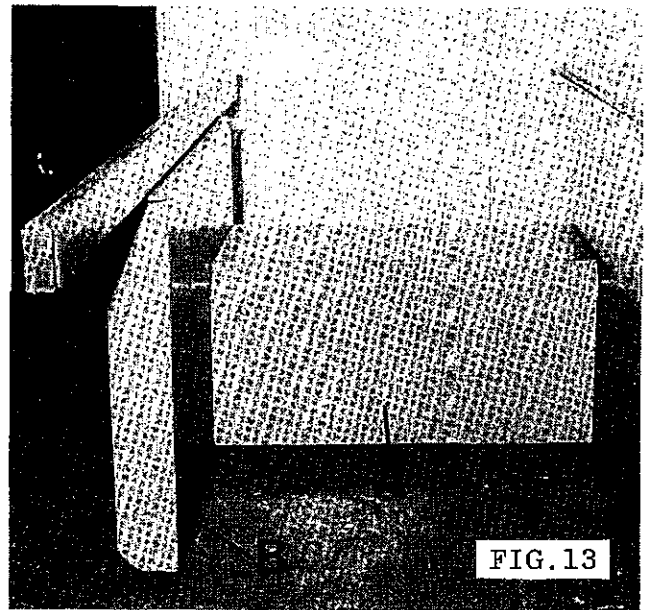
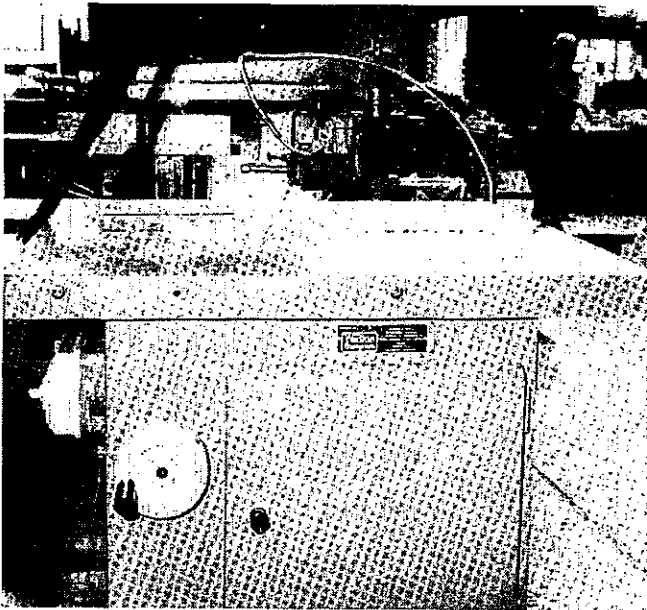

FIG. 13

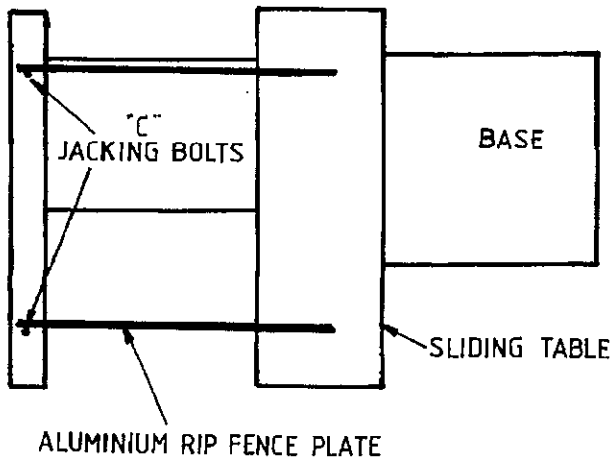

FIG. 14

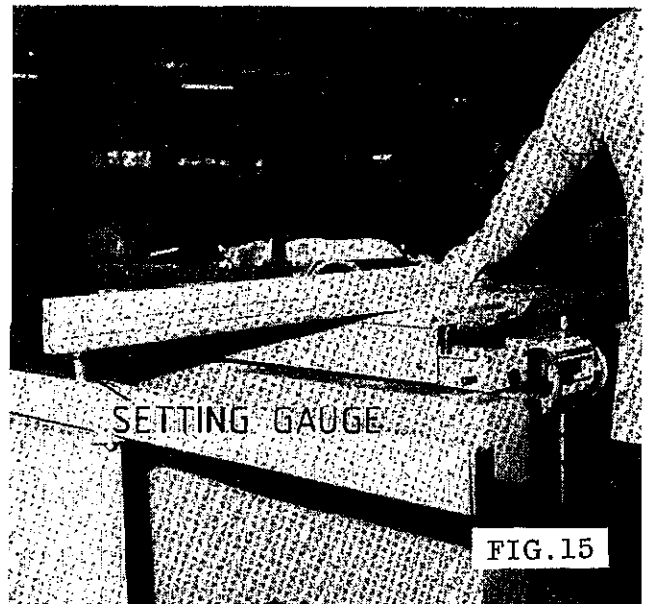

FIG. 15

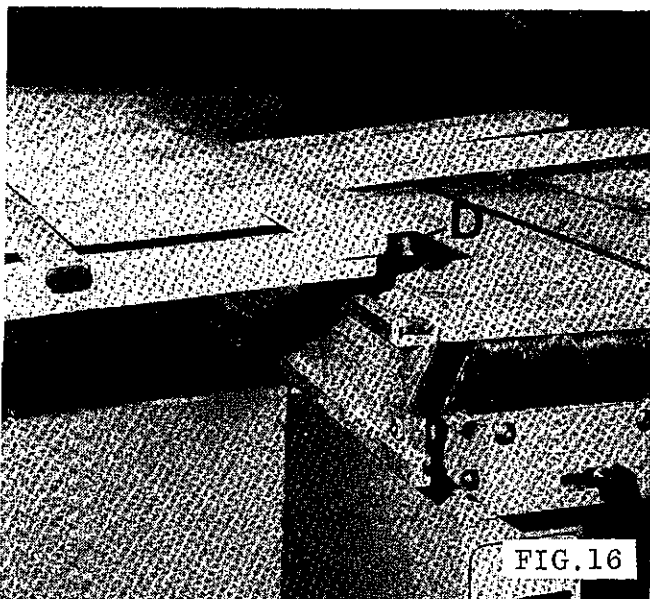

FIG. 16

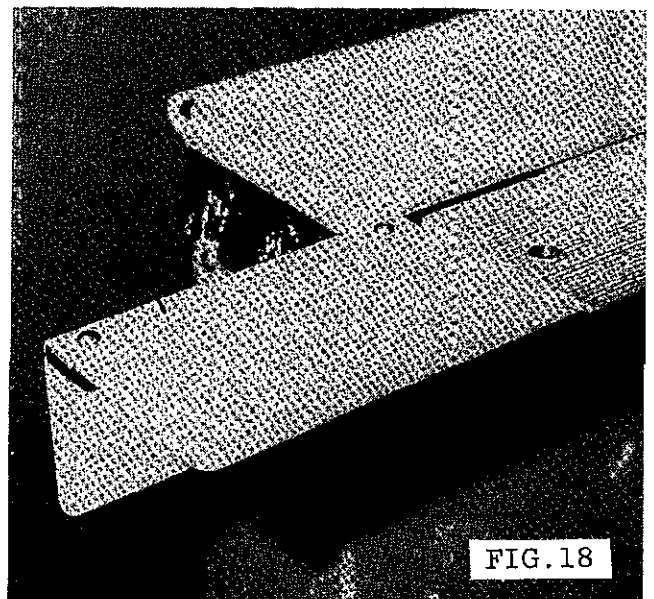

FIG. 18

ASSEMBLY OF MACHINE - CP12

When the machine is for the home market, the outer support, tie piece, outrigger table, crosscut fence, rip fence and scorer guards are removed for the ease of transportation.

When the machine is for the export market, the outer support is packed in a separate case, the tie piece, outrigger table, crosscut fence and rip fence are removed and packed with the machine.

To assemble outrigger table, proceed as follows:-

- 1 Firmly secure tie piece "A" FIG.13 to base with 4-M8 studs and nuts provided, then position outer support "B" to tie piece with 4-M8 studs and nuts provided.

NOTE: ENSURE JACKING BOLTS IN OUTER SUPPORT ARE FLUSH WITH SUPPORT BEFORE SECURING TO TIE PIECE.

- 2 Position aluminium rip fence plate FIG.15 over sliding table and outer support above each jacking bolt "C" FIG.14, check height with setting gauge provided FIG.15, jack bolt (FIG.17) to suit setting gauge.

- 3 Position outrigger table over outer support and locate spiggots "D" into shoes in sliding table slot FIG.16.

The crosscut fence is fitted to the front of the sliding table and positioned square to the saw. It is held by a pivot pin on the outrigger table and a spring loaded plunger on the sliding table. For ripping operation lock sliding table FIG.21. Release spring loaded plunger and swing crosscut fence clear.

To re-assemble rip fence, proceed as follows and refer to FIG.24:-

Locate studs "N" into holes in front of main table. Set parallel to table top and lock in position with nuts provided.

NOTE: DO NOT DISTURB LOCKNUTS AS THESE ARE SET IN FACTORY TO GIVE CORRECT FENCE ALIGNMENT.

Assemble fence and put stop screw in end of fence bar. Fit fence support "O" to table edge and ensure support is set level to table top.

Fit front and rear sliding table guard "E" FIG.18(home orders only) into tee slot on sliding table and lock into position with allen key supplied.

NOTE: ON CP12/D THE RIP FENCE IS THE ONLY PART REMOVED, RE-ASSEMBLE AS CP12.

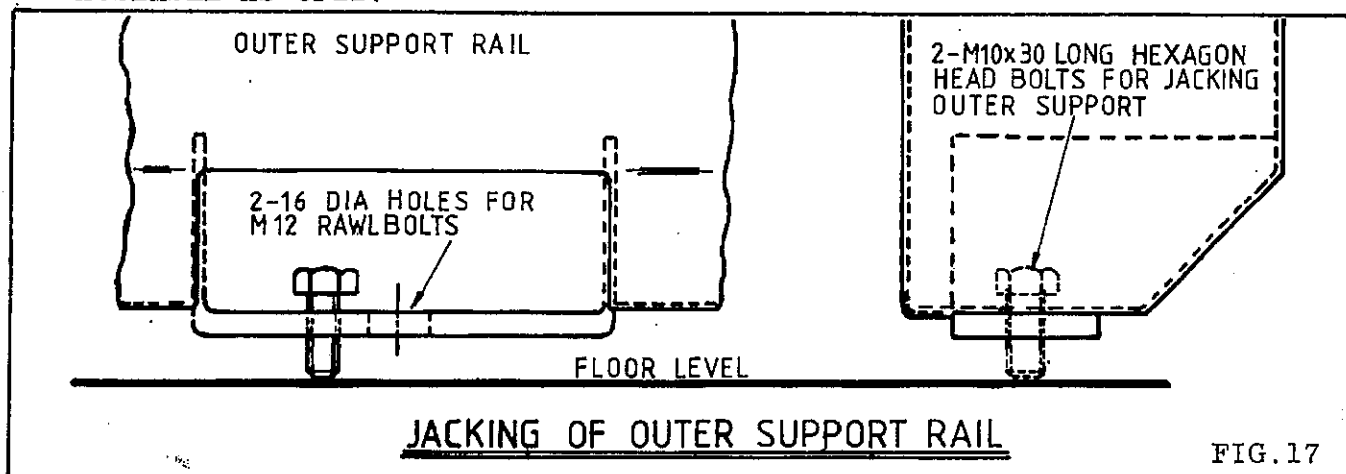



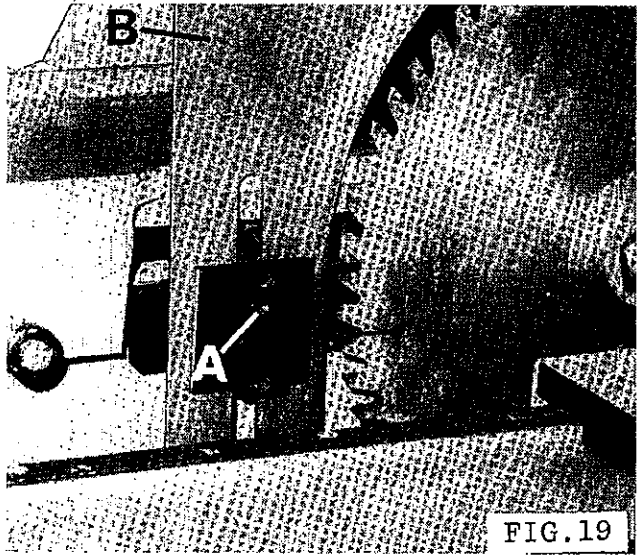

FIG. 19

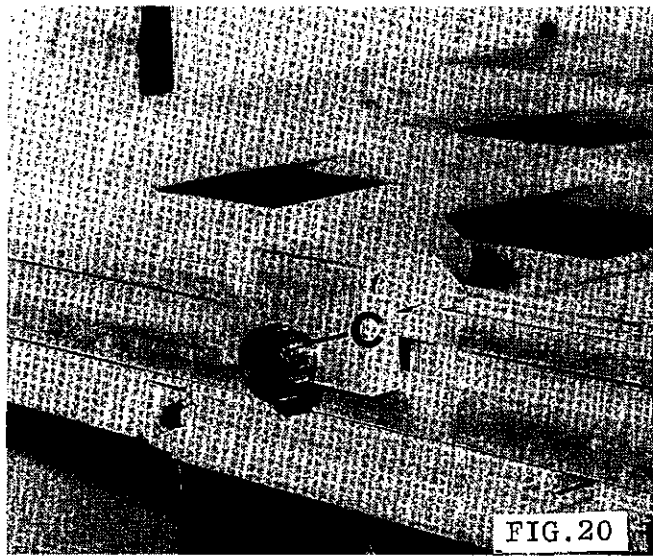

FIG. 20

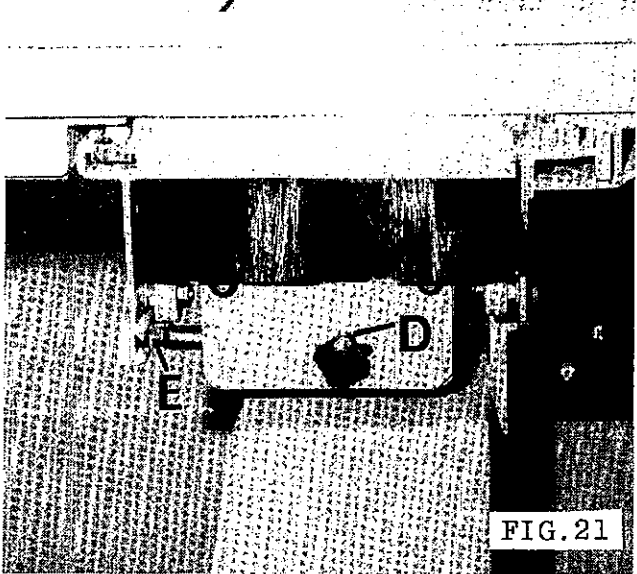

FIG. 21

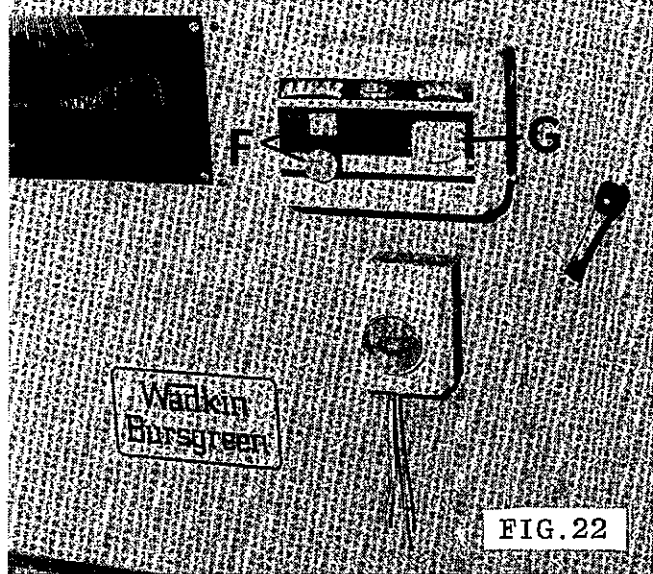

FIG. 22

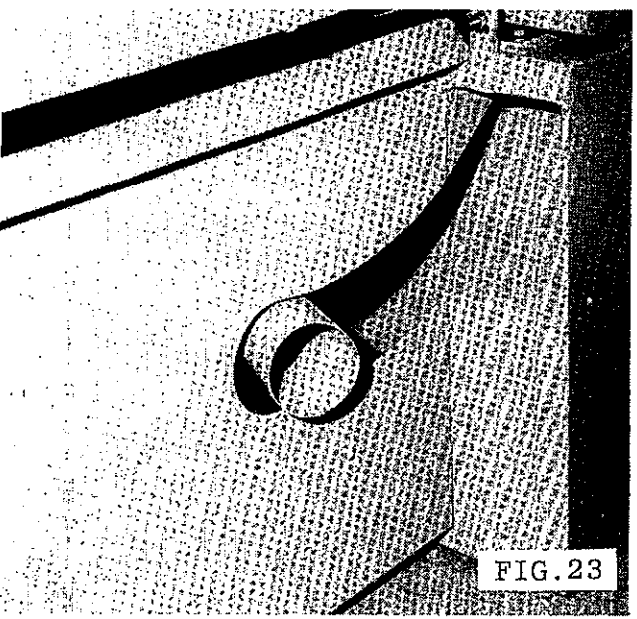

FIG. 23

### GUARD AND RIVING KNIFE ADJUSTMENT

The riving knife and guard rise and fall with the saw. The riving knife should be adjusted to the closest practicable distance from the saw teeth.

To adjust the riving knife to this position, proceed as follows:-

- 1 Isolate machine electrically.
- 2 Move sliding table for access to riving knife adjustment FIG.19.
- 3 Loosen M16 socket head screw "A" and move riving knife "B" to correct position.
- 4 Tighten securely socket head screw "A".

The sawguard should then be adjusted to cover as much of the saw as possible.

### TURN OVER STOPS

2 - Turn over stops are supplied with machine and are fitted to the crosscut fence as shown in FIG.20. These stops are fitted to enable timber to be positioned in correct relation to sawblade and for repeat cuts on same size timber.

To move each stop, loosen handwheel "C", position stop as required then relock handwheel "C".

### POSITIONING OF SLIDING TABLE CARRIAGE

At the start of each working day push sliding table to maximum forward position then to maximum rear position to ensure sliding table carriage is correctly positioned in relation to table stops. This will avoid "shuffling" of table and carriage.

### SLIDING TABLE LOCK

When the machine is used for ripping operations the sliding table can be locked by locating the locking bar "D" between domed nuts "E" as shown in FIG.21.

### MAIN SAW START-STOP

Main saw start-stop buttons "F", FIG.22 are conveniently situated on front of machine.

### SCORING SAW START-STOP SWITCH

The scoring saw start-stop switch "G", FIG.22 is conveniently situated on front of machine.

### ISOLATOR SWITCH (Optional Extra)

A lockable isolator switch is fitted on below the control boxes shown in FIG.22.

### EXHAUST OUTLET

This is situated at rear of machine FIG.23, and if required can be fitted to a dust exhaust system.

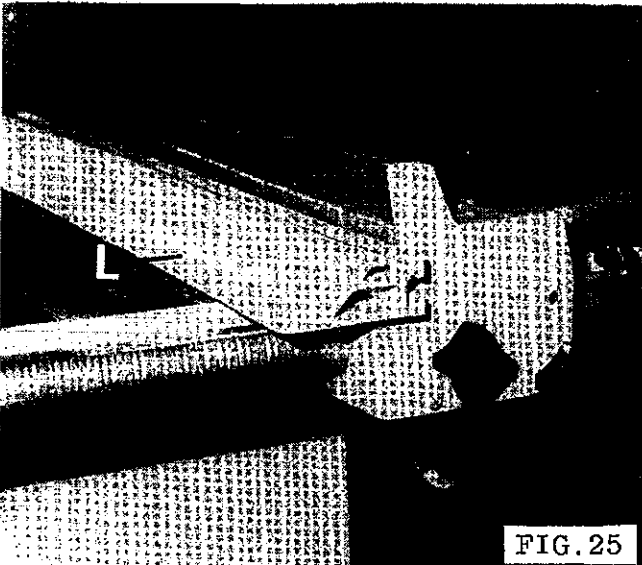
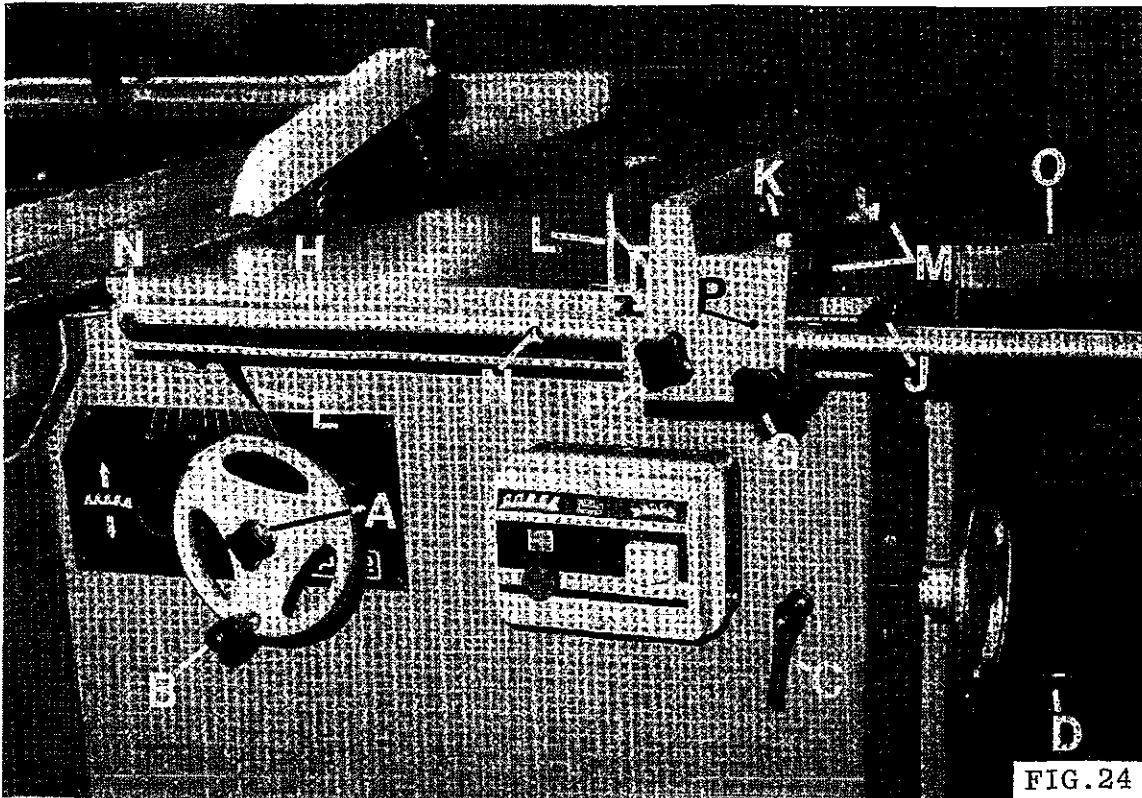

#### RISE AND FALL CONTROLS

For rise and fall of saw arbor, proceed as follows:-

Release locking handle "A" in FIG.24, and raise or lower the saw arbor by the handwheel "B" to the required position, then re-lock handle "A"

#### CANTING CONTROLS

The saw cants  $45^{\circ}$  to the right with positive stops at  $90^{\circ}$  and  $45^{\circ}$ . For canting of saw arbor, proceed as follows:-

Release locking handle "C" in FIG.24, and turn handwheel "D" working in conjunction with the canting scale indicated by the pointer "E" to the required saw position. Re-lock handle "C".

### RIP FENCE CONTROLS

The rip fence slides on a round bar fitted to front of table. Rapid fence adjustment and micro-adjustment are provided with an effective lock.

For rapid fence adjustment, proceed as follows:-

- 1 Loosen handwheel "F", FIG.24.
- 2 Position fence where required then turn handwheel "F" to lock fence in position. A ripping capacity scale on fence slide bar "H" is indicated by an adjustable pointer "J" located in the fence body and secured by grubscrew "P".
- 3 For micro-adjustment, engage spring loaded handwheel "G" in the racked fence slide bar, i.e. handwheel "G" pushed into the fence front bracket.

### Fence Plate Positions

The fence plate "L" in FIG.24, has two positions. Position shown in FIG.24, is for use with deep stock, fence can be moved longitudinally to facilitate this. Position shown in FIG.25, is for use with faced panels, melamine, veneer, etc.

To change the fence plate position, proceed as follows:-

- 1 Loosen handwheels "M" in FIG.24, then slide fence plate "L" from fence body.
- 2 Slide fence plate over the two locking plates to position shown in FIG.25, then relock handwheels "M".

### Fence Pointer Adjustment

When the fence plate position has been changed as previously described, the pointer "J" in FIG.24, must be reset accordingly.

To reset pointer, proceed as follows:-

- 1 Loosen handwheel "F", FIG.24, then move fence to a position which would allow a reasonable cut to be taken. Turn handwheel "F" to lock fence in position.
- 2 Start machine, then feed a piece of timber past the sawblade keeping timber firmly against the fence. Stop machine.
- 3 Accurately measure the width of timber then loosen grubscrew "P", and set rule pointer "J" accordingly. Relock grubscrew "p".

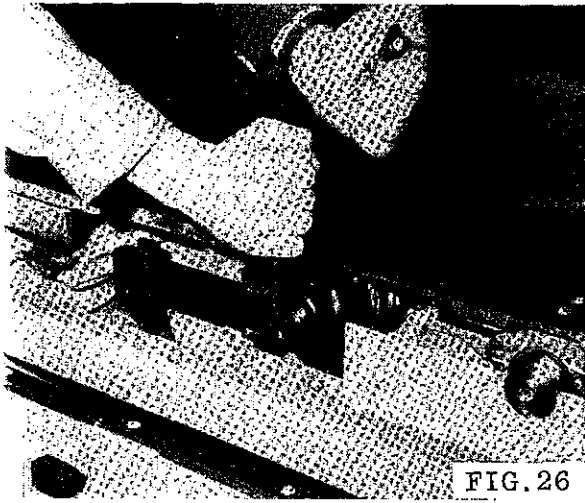

FIG. 26

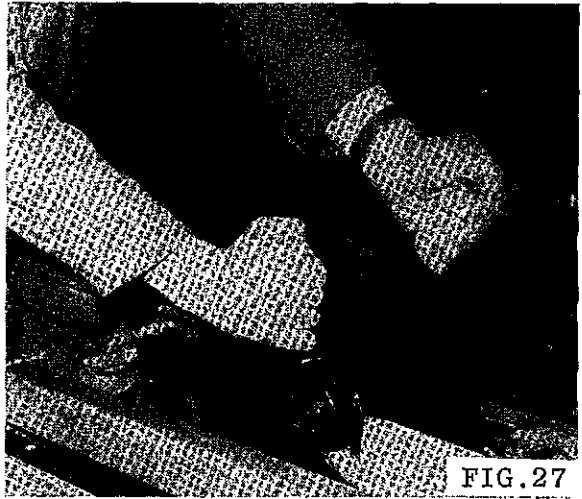

FIG. 27

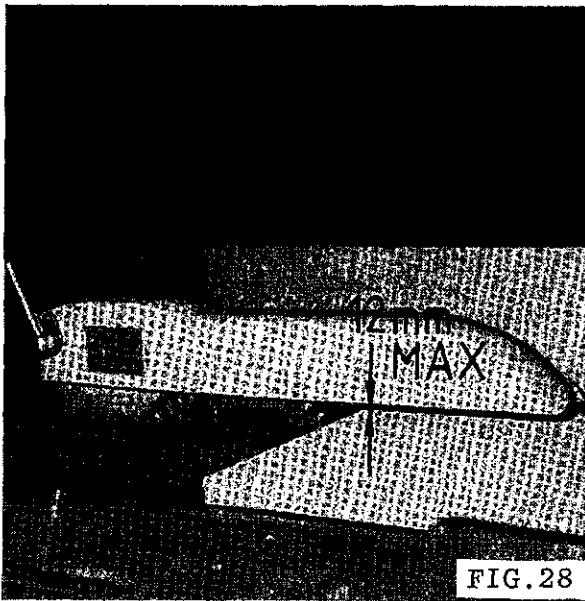

FIG. 28

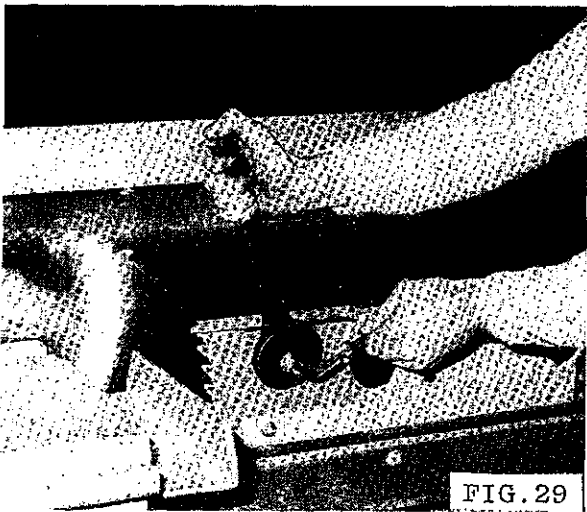

FIG. 29

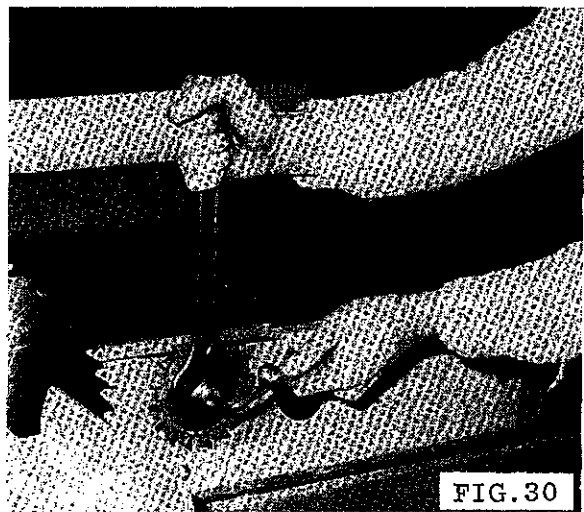

FIG. 30

### MOUNTING MAIN SAW BLADE

To mount the main sawblade, proceed as follows:-

- 1 Isolate machine electrically.
- 2 Move saw spindle to uppermost position.
- 3 Move sliding table for access to main sawblade.
- 4 Locate 8mm allen key (supplied) in main saw spindle as shown in FIG.26, then remove arbor nut (left hand thread) with 36mm A/F spanner (supplied) and front sawflange.
- 5 Select required blade (300 dia max. if scoring is required), and check blade is free from dirt, gum or sawdust, especially where it will be gripped by saw flanges. Check rear saw flange is clean and fit saw on arbor.

NOTE: Saw teeth must point towards front of machine. Check front saw flange is clean and fit on arbor.

NOTE: If flanges and saw are not clean, the saw will run out of true causing vibration.

- 6 Lock saw securely in position with arbor nut (left hand thread) as shown in FIG.27.
- 7 Position sawguard depending on thickness of timber to be worked.

NOTE: Sawguard must cover blade as much as is practicable. Clearance between sawguard and timber should never exceed 12mm, FIG.28 (Woodworking Machine Regulations 1974 16(3)).

### MOUNTING SCORING SAWBLADE

To mount the scoring sawblade, proceed as follows:-

- 1 Isolate machine electrically.
- 2 Move sliding table for access to scoring saw.
- 3 Locate 8mm allen key (supplied) in scoring saw spindle as shown in FIG.29 and remove scoring saw nut (right hand thread) with 32mm A/F spanner (supplied).
- 4 Fit scoring saw with teeth pointing towards rear of machine, FIG.30.

NOTE: See FIG.34 for use of shims as fitted between scoring saw blades for correct kerf alignment.

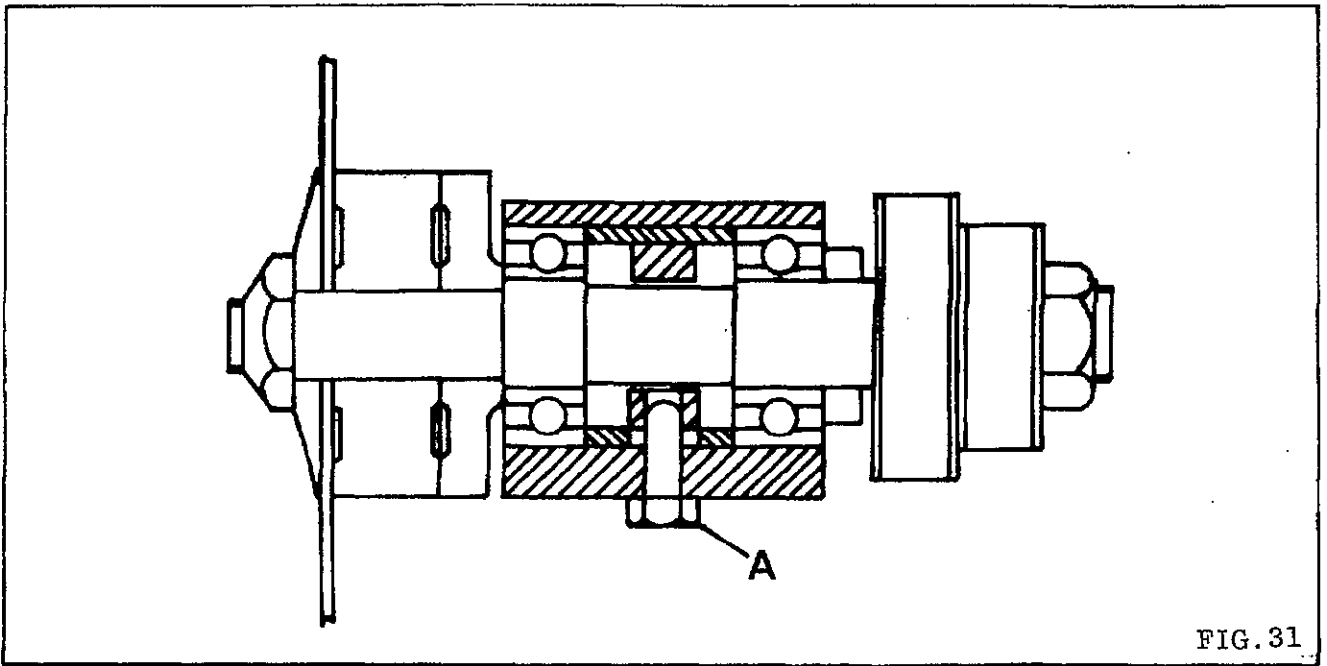

FIG. 31

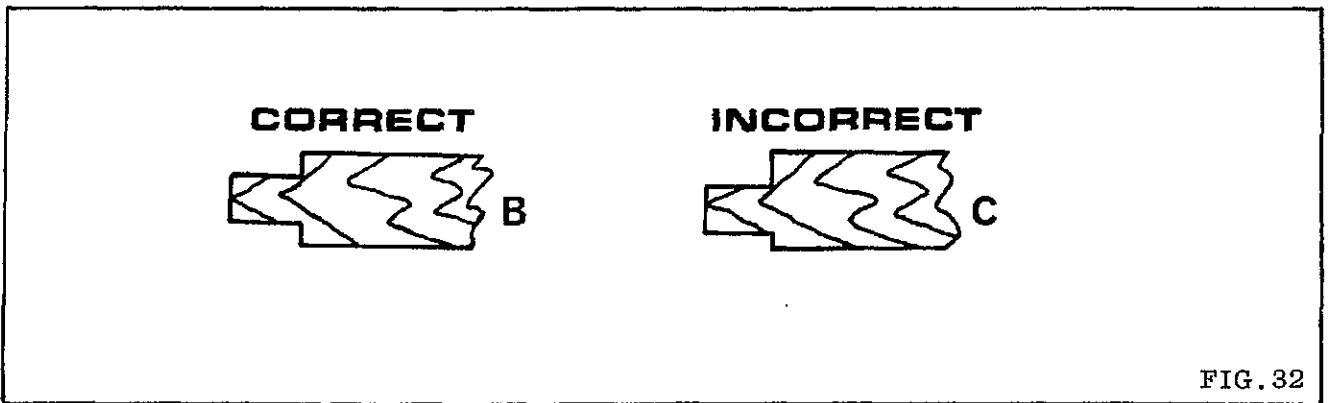

FIG. 32

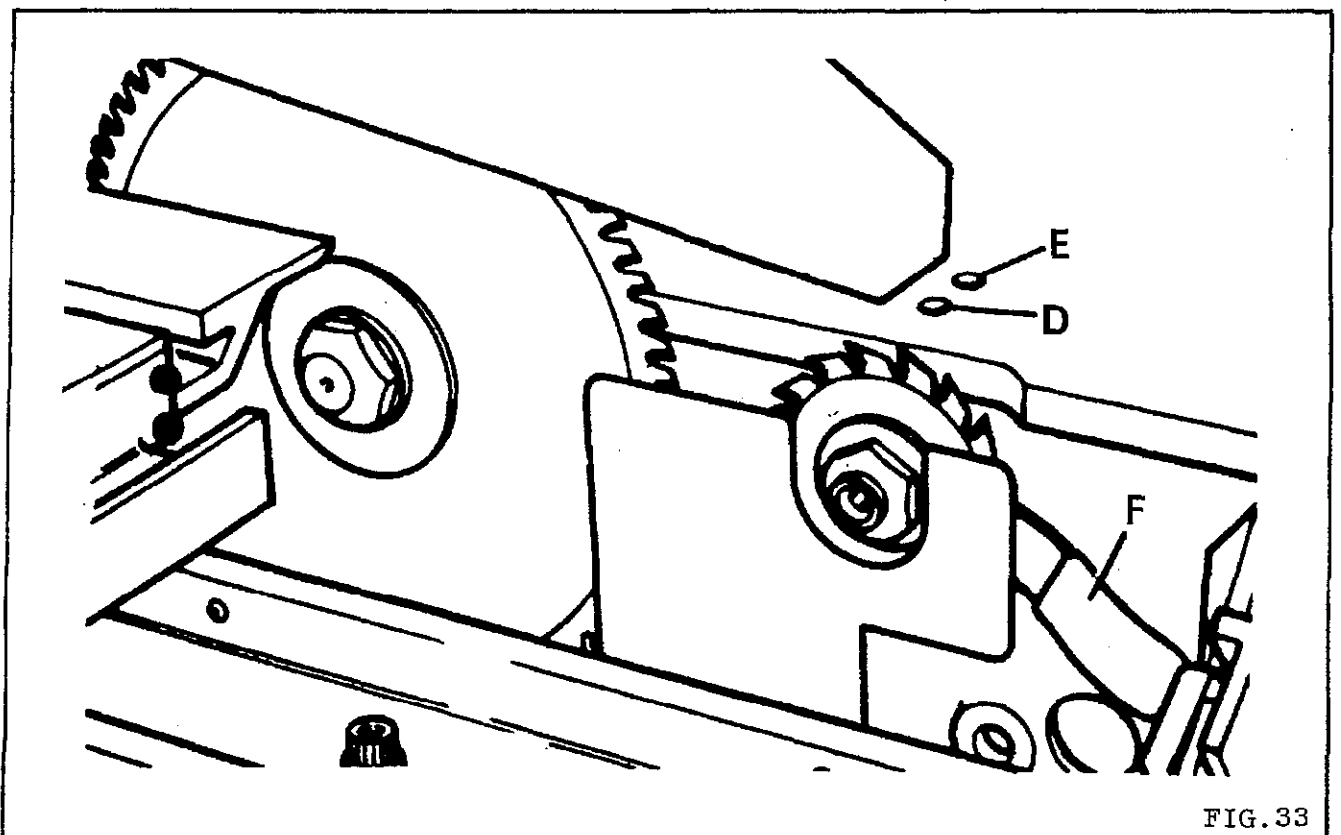

FIG. 33

### SETTING SAW TO RIVING KNIFE

It is most important that the saw and riving knife are in line. To re-set if spindle bearings have been changed or saw is cutting out of line, proceed as follows:-

- 1 Loosen the hexagon head adjuster bolt "A" in FIG.31, and tap spindle (with hide-face hammer) as required, taking care not to damage the threads on spindle ends.  
Place a steel rule along both sides of riving knife to check that saw is central.
- 2 When set re-tighten the hexagon head bolt "A".
- 3 To check this setting, feed a short piece of timber from the rear, along both sides of the riving knife. If riving knife is set correctly the blade will cut equal shoulders as shown in FIG.32B and when set incorrectly, unequal shoulders as shown in FIG.32C.

### SCORING SAW

Is designed to prevent splching of all materials including plywood, fibreboard, chipboard, thicker solid plastics and materials having two face layers of veneer, etc.

A twin blade scoring saw is supplied with 3 shims of 0.010", 0.005" and 0.003" thick. These shims can be positioned between the blades as required to ensure the scoring saw kerf is identical to, or wider than, the main saw kerf.

Scoring saw lateral and vertical adjustments are provided to ensure accurate alignment to thickness of main saw blade so that brittle materials can be cut with perfect finish on upper and lower edges at both sides of cut.

### SCORING SAW ALIGNMENT TO MAIN SAWBLADE

- 1 Place a steel rule or similar straight edge across main blade and scoring blade to check approximate lateral alignment.
- 2 Lateral adjustment to scoring blade is by releasing 8mm socket head cap screw lock "D" in FIG.33 (8mm allen key supplied) then adjust blade laterally by 8mm socket head cap screw "E". When set correctly, re-lock socket head cap screw "D".
- 3 Adjust scoring blade vertically by loosening 8mm socket head cap screw lock "D" in FIG.33, then move blade vertically by lever "F". When set correctly, re-lock socket head cap screw "D". Correct vertical adjustment is attained when the scoring saw scores the full underside length of panel.  
NOTE: Some panels may be badly bowed in which case the scoring saw should be vertically adjusted to suit.
- 4 Proceed to take trial cuts to establish the accuracy of the alignment of the scoring blade with main blade. The correct alignment is shown in FIG.34.



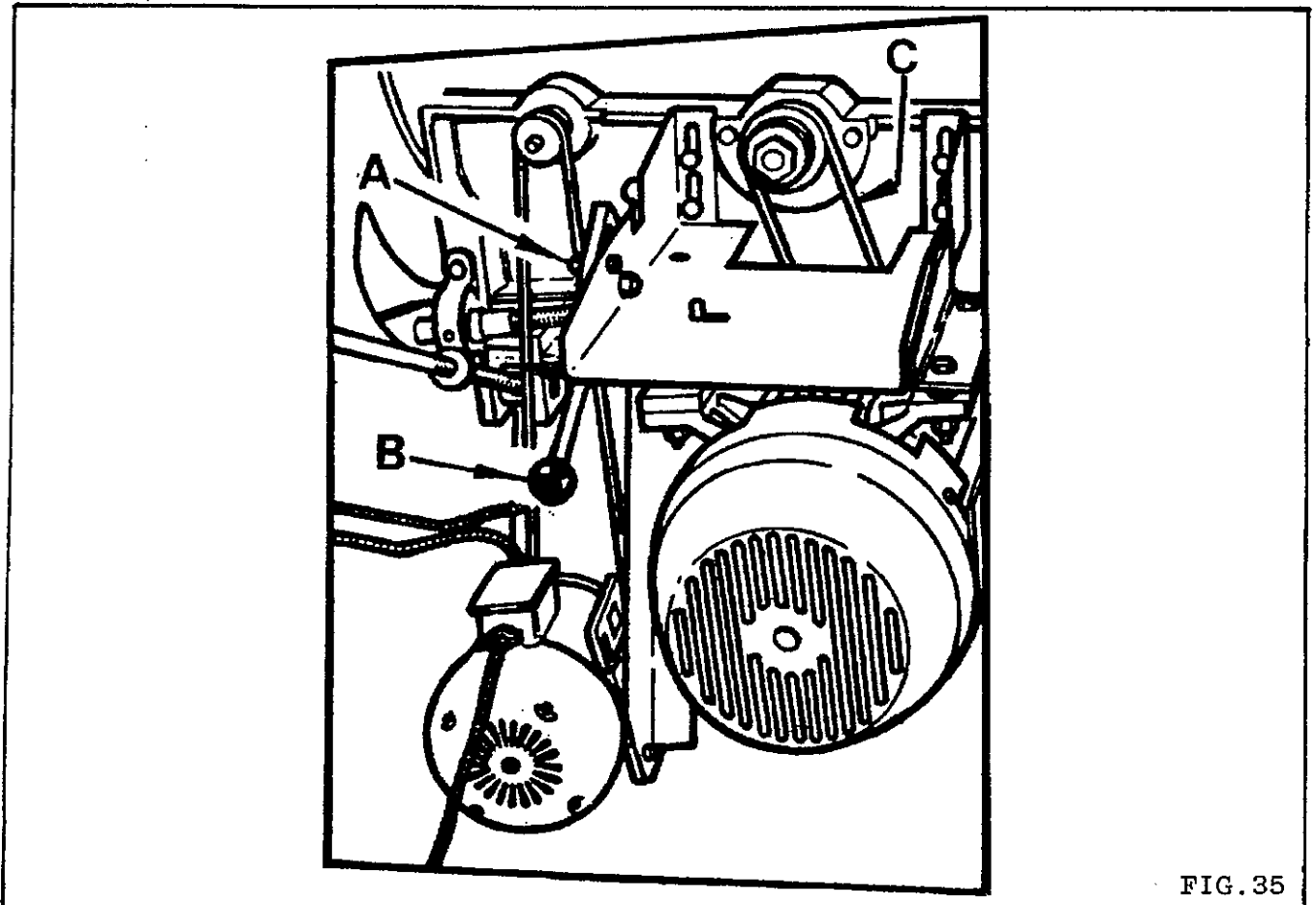
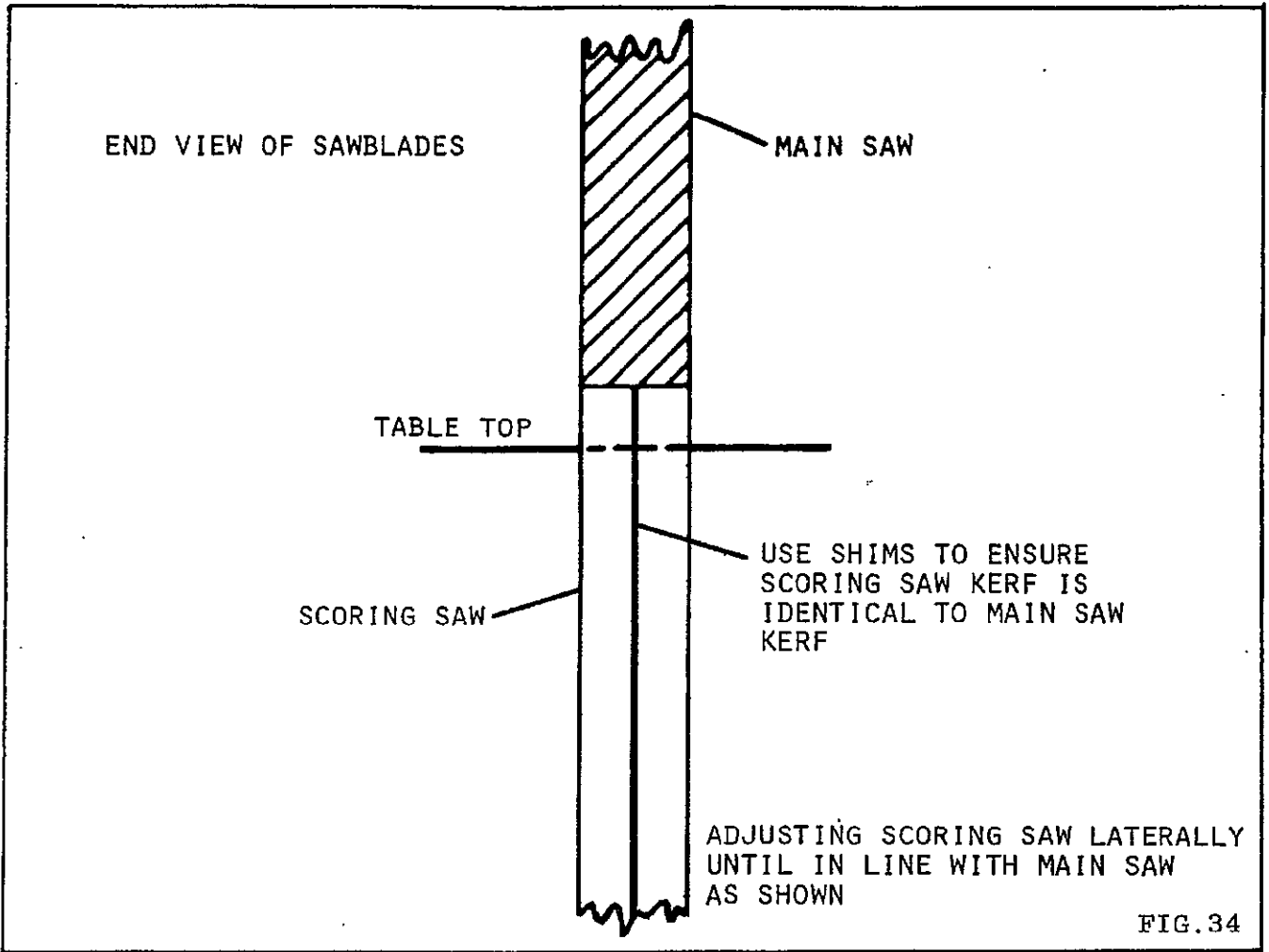

## GENERAL MAINTENANCE

### SAW SPINDLE SPEED CHANGING OR BELT CHANGING

The saw spindle is driven by 1 "Poly Vee" belt on a 2 step pulley from the main motor giving speeds of 3000 rpm and 4000 rpm at 50 cycle.

To change belt for required speed, proceed as follows:-

- 1 Isolate machine electrically.
- 2 Open access door at side of machine.
- 3 Loosen locking handle "A" in FIG.35 and move handle "B" to release belt tension. Hold motor in this position and securely lock locking handle "A".
- 4 Change belt "C" to required pulley on spindle pulley and motor pulley. See pulley diagram FIG.36 for required spindle speed.
- 5 When belt has been changed, hold handle "B" in FIG.35 and loosen locking handle "A" then pull handle "B" to apply tension to belt.  
NOTE: Belt tensioned too tight will cause bearing failure. Belt tensioned too slack will cause belt slip.
- 6 When belt is tensioned correctly securely tighten locking handle "A".
- 7 Close access door at side of machine.

IMPORTANT: DO NOT RUN LARGE SAWBLADES AT HIGH SPEED.

### BELT CHANGING ON SCORING MOTOR

To change belt on scoring motor, proceed as follows:-

- 1 Isolate machine electrically.
- 2 Open access door at side of machine.
- 3 Pivot motor by hand to change belt.  
NOTE: Weight of motor tensions belt.
- 4 Close access door at side of machine.

SPINDLE PULLEY

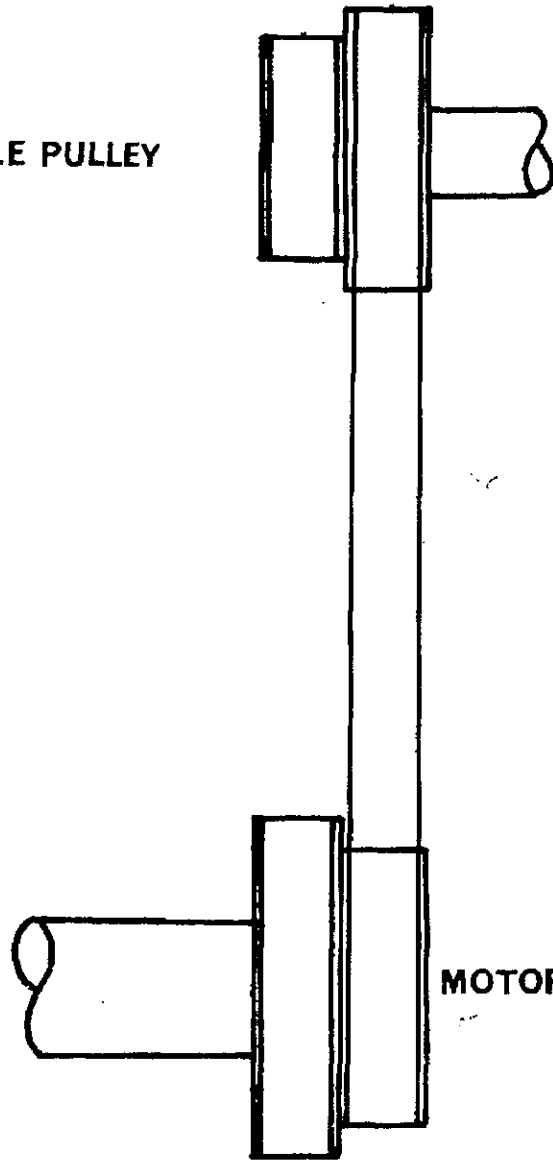

MOTOR PULLEY

FIG. 36

SAFETY SECTION

All safety precautions should be taken to comply with relevant safety regulations, ie Woodworking Machines Safety Regulations 1974 - No.903 (Great Britain). Always adjust the riving knife and guard to protect as much of the saw as is possible. These adjustments have been previously described.

Do not use sawblades at higher than recommended speed. When changing sawblades, belts, lubricating or any other maintenance, always isolate the machine electrically. Use a wood push stick as much as practicable when feeding timber to avoid accidents.

SAWBLADES

For best results we recommend the purchase of sawblades from BURSGREEN (DURHAM).

Sawblades available:-

400mm diameter x 30mm bore alloy rip sawblade B-S-239  
 400mm diameter x 30mm bore alloy crosscut sawblade B-S-240  
 300mm diameter x 30mm bore TCT sawblade B-S-242  
 105mm diameter x 20mm bore TCT split scoring sawblade B-S-230

Do not use sawblades at higher than recommended speed.

NOTE: WHEN USING 400mm DIAMETER SAWBLADE, STANDARD RIVING KNIFE MUST BE REPLACED BY RIVING KNIFE 1086/36, (WHICH CAN BE OBTAINED AT AN ADDITIONAL CHARGE).

BEARINGS

1 - SY20LX	Rise & Fall
1 - FYTB 205D	Trunnion
2 - 6206 2RS	Saw Spindle
2 - 6003 2RS	Scorer
8 - CGR Rollers	Sliding Table

BELTS

1 - Poly-V-Belt	300 J10
1 - Poly-V-Belt	460 J4

Application	APPROVED LUBRICANTS					
	Castrol	B.P.	Shell	Esso	Texaco/Caltex	Wadkin
Worm Boxes	ZN220	Energol CS320	Vitrea 320	Spartan EP220	Regal Oil 320	L2
General Lubrication	Magna 68	Energol HP68	Vitrea 68	Nuray	Ursa Oil P68	L4
Pneumatic Lubricators	Hyspin AWS32	Energol HL32	Tellus 37	Nuto H32	Rando Oil HD32	
Grease	Spheerol AP3	Energol L53	Alvania R3	Beacon 3	Regal Starfak Premium 3	L6
Brake Cables	Brake Cable grease	Energol L21M	Alvania R3	Esso Multi-purpose grease		

**Wadkin**  
**Bursgreen**

**ILLUSTRATED  
PARTS  
LIST**

ASSEMBLY:- BASE			
FIG ITEM	PART NO. *	UNITS PER ASSEMBLY	DESCRIPTION
1	CP12/9	1	Table
2	P32/328	1	Door
3	1247 ADS	1	MEM Starter with Scorer Switch T1-2/e (415-3-50)
	1237 ADS	1	MEM Starter with Scorer Switch T1-2/e (380-3-50)
	1617 ADS	1	MEM Starter with Scorer Switch T1-2/e (220-3-50)
4	CP12/1	1	Base
5		1	Nameplate
6	CP12/5	1	Canting Pointer
7	CP12/4	1	Front Plate

- ITEM NOT ILLUSTRATED

\* PLEASE QUOTE PART & MACHINE  
NUMBER WHEN ORDERING SPARES

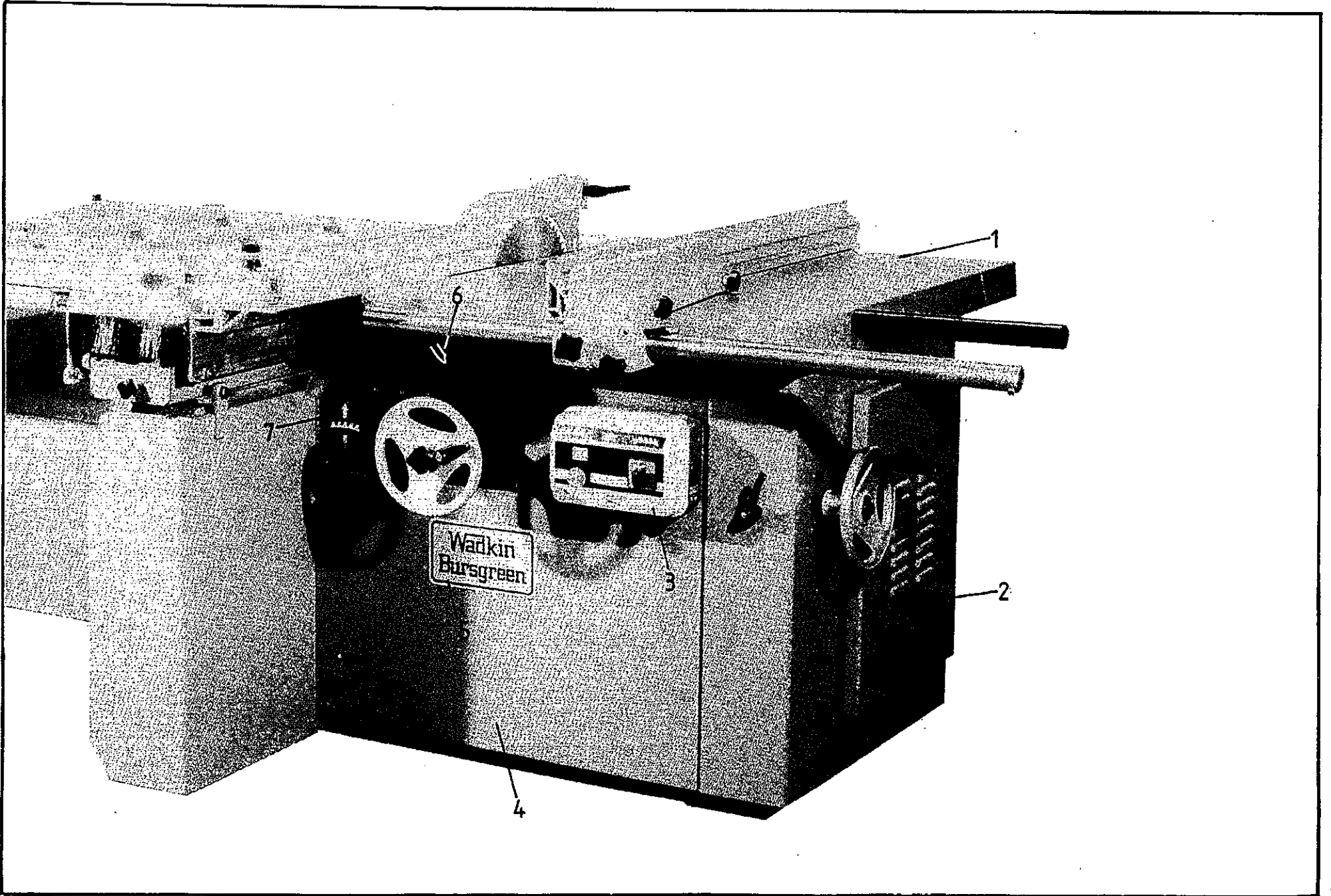



## ILLUSTRATED PARTS LIST

### ASSEMBLY:- OUTER SUPPORT FOR OUTRIGGER TABLE

FIG ITEM	PART NO. *	UNITS PER ASSEMBLY	DESCRIPTION
15	CP12/2	1	Tie Piece
16	K05-26-233	8	Studs for Tie Piece
17		8	8mm Washers
18		8	M8 Nuts
19	SP12/120	1	Outer Support
20	1026/22	2	Washers
21		2	M10 Nuts
22		2	M10 x 30 Long Studs
23	SP12/67	1	Outer Support Rail
24	K51-61-181	2	Ribbed Inserts

- ITEM NOT ILLUSTRATED

\* PLEASE QUOTE PART & MACHINE  
NUMBER WHEN ORDERING SPARES



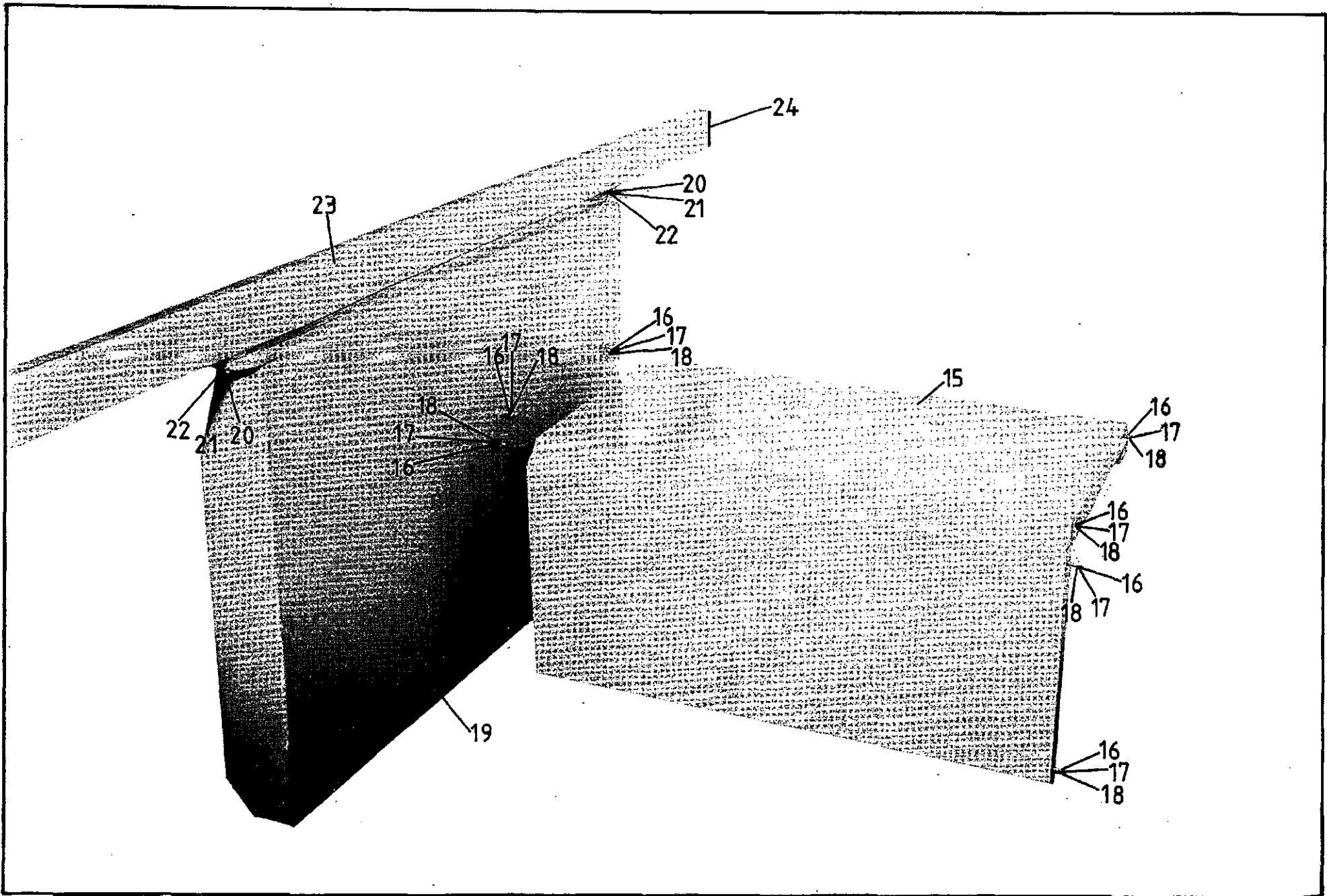

# Wadkin Bursgreen

## ILLUSTRATED PARTS LIST

### ASSEMBLY:- OUTRIGGER TABLE

FIG ITEM	PART NO. *	UNITS PER ASSEMBLY	DESCRIPTION
40		1	M10 Aerotight Nut
41	S25/418	1	Knock Down Stop
42		1	M10 x 25 Long Hexagon Set Screw
43	SP12/158	1	Outrigger Table
44	3092	4	Blanking Plugs
45		1	M8 x 16 Long Hexagon Set Screw
46	1041/88	1	Washer
47		6	M8 x 16 Long Socket Set Screws
48	SP12/53	2	Shoe for Outrigger
49		4	M6 x 12 Long Pan Head Screws
50	SP12/69	2	Felt Wiper for Outrigger
51	SP12/76	2	Trapping Plate for Wiper
52		2	M10 x 65 Long Hexagon Set Screws
53	SP12/55	4	Bearing Distance Pieces
54	0.4705.00	2	CGR Rollers
55		2	M10 Nuts

- ITEM NOT ILLUSTRATED

\* PLEASE QUOTE PART & MACHINE  
NUMBER WHEN ORDERING SPARES

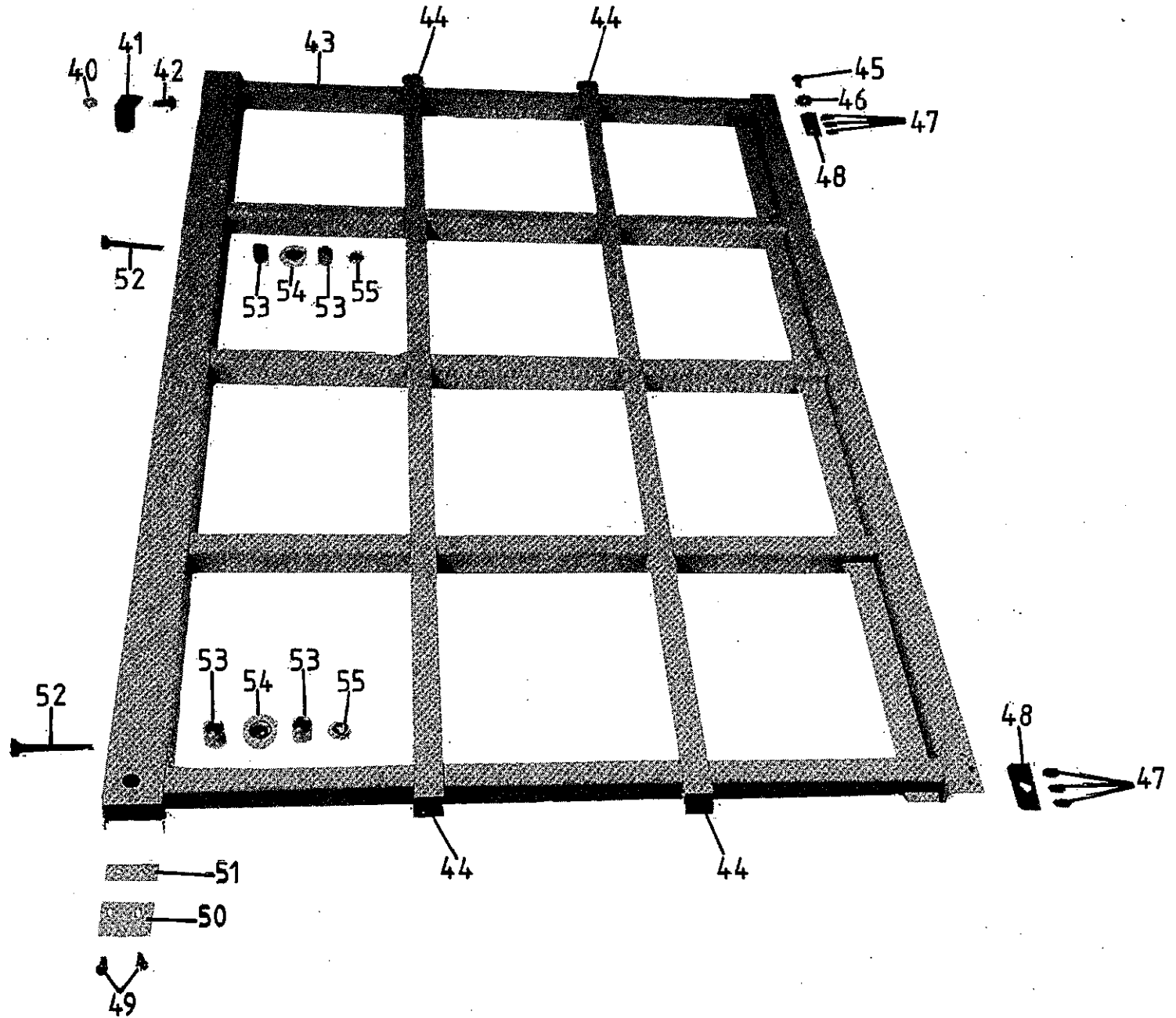

# Wadkin Bursgreen

## ILLUSTRATED PARTS LIST

ASSEMBLY:- SLIDING TABLE			
FIG ITEM	PART NO. *	UNITS PER ASSEMBLY	DESCRIPTION
60	Patt 98	1	M8 Locking Knob
61	1041/88	1	Washer
62	1079/654	1	Spacer
63		1	M8 x 40 Long Stud
64	P32/49	1	Locking Plunger
65		2	M8 Dome Nuts
66		2	M8 x 12 Long Countersunk Machined Screws
67		2	8mm Washers
68		4	M10 x 20 Long Socket Button Head Screws
69	CP32/18	1	End Plate for Beam with Lock
70	P32/283	2	Beam Adjusting Studs (Underside of Beam)
71	P32/286	4	Beam Adjusting Screws (Underside of Beam)
72		4	M12 Nuts (Underside of Beam)
73	1014/201	2	Washers (Underside of Beam)
74		2	M16 Nuts (Underside of Beam)
75	SP12/6	1	Beam
76	SP12/62	1	Stop for Beam
77		2	M8 x 20 Long Socket Capscrews
78	CP32/19	1	End Plate for Beam
79	SP12/11	2	Covers for Carriage
80		6	M6 x 10 Long Socket Head Button Screws
81	CP32/61	2	Diabalo Trapping Brackets
82	CP32/16	2	Diabalo Rollers
83	SP12/13	1	Carriage
84	SP12/60	2	Stops for Sliding Table
85	BRA 69	2	Rubber Stops (Fitted either end of Carriage
	BRA 69	2	Rubber Stops (Fitted either end of Sliding Table)
86		4	M10 x 12 Long Pan Head Machined Screws
87			Undertable Roller Assembly
88	SP12/113	1	Sliding Table
89		8	M10 Nuts
90	0.4705.00	8	CGR Rollers
91	SP12/72	8	Eccentric Pins for Under Table Rollers
92		8	10mm Washers
93		8	M10 Locknuts

- ITEM NOT ILLUSTRATED

\* PLEASE QUOTE PART & MACHINE  
NUMBER WHEN ORDERING SPARES

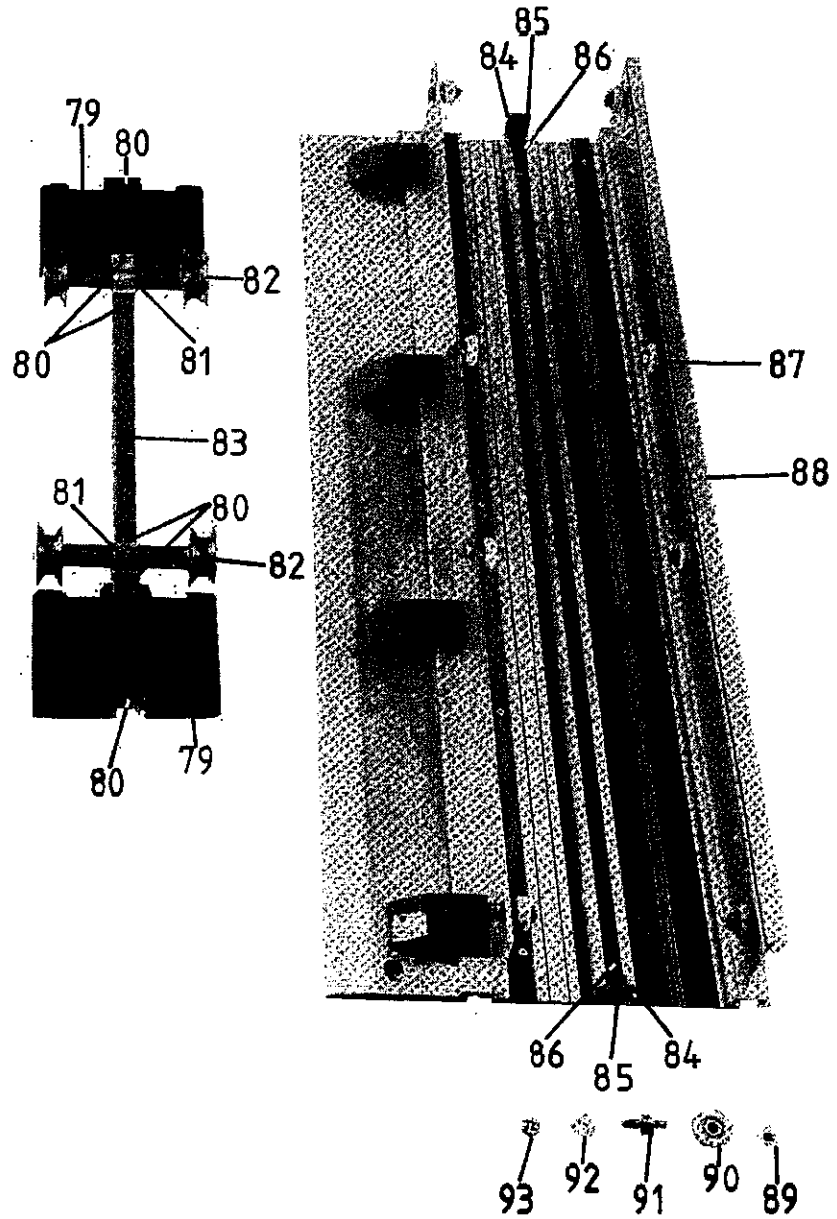
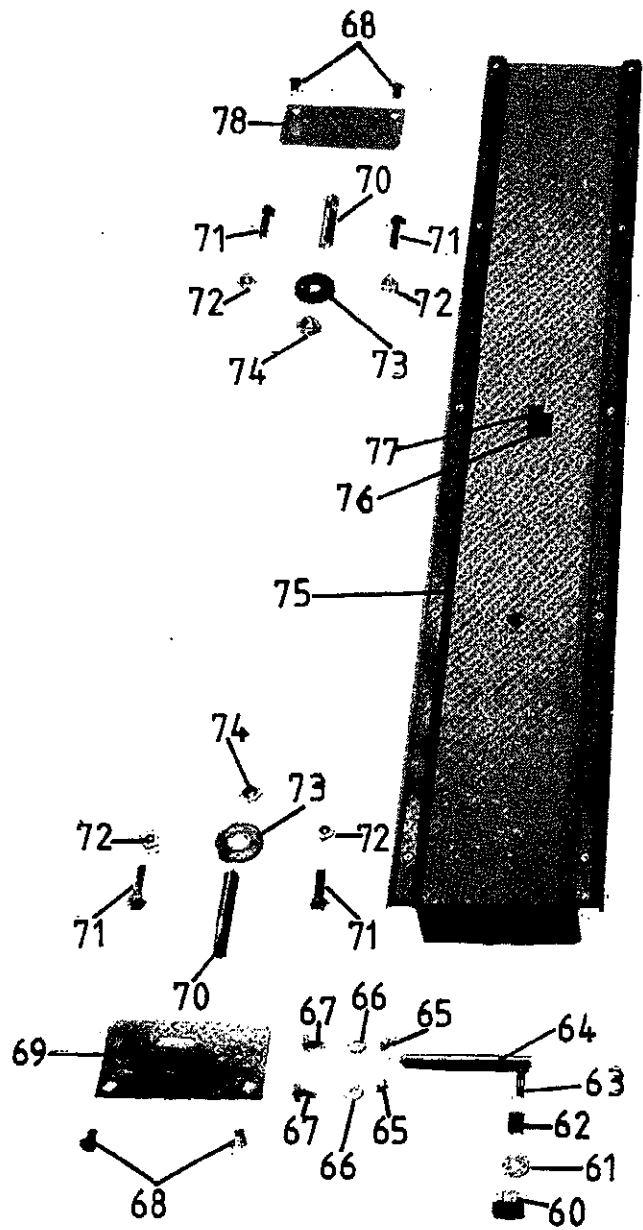

# Wadkin Bursgreen

## ILLUSTRATED PARTS LIST

### ASSEMBLY:- RISE AND FALL AND TRUNNION

FIG ITEM	PART NO. *	UNITS PER ASSEMBLY	DESCRIPTION
100	CP32/45	1	Trunnion Bracket
101	1073/1	1	Rise and Fall Bracket
102		1	M10 x 60 Long Countersunk Screw
103	1073/48	1	Rise and Fall Bracket Packing Piece
104		1	M10 x 110 Long Hexagon Set Screw
105		1	M10 x 60 Long Hexagon Set Screw
106	1073/56	1	Rise and Fall Bracket Trapping Plate
107	CP32/64	1	Canting Screw
108	CP32/25	3	Stop Nuts
109		6	M6 x 6 Long Socket Set Screws
110	CP32/26	3	Stop Collar
111	CP32/27	1	Canting Nut
112	7100 035	2	35mm External Circlips
113	7100 020	2	20mm External Circlips
114	K05-26-277	1	Canting Screw Lock Stud
115	1073/127	1	Canting Lock Bush
116		1	Grommet
117		1	M10 Bristol Locking Handle
118		2	M10 Nuts
119		2	10mm Washers
120		3	M10 x 25 Long Hexagon Set Screws
121	FYTB 205D	1	'Y' Bearing Flange Unit
122	BEL 86	1	Handwheel
123	BEL 37	2	Handle for Handwheel
124	BEL 38	2	Spindle for Handwheel
125	SP12/145	1	Handwheel
126	K51-27-139	1	M10 Handwheel
127		1	M10 x 30 Long Stud
128	1069/293	1	Handwheel Washer
129	CP32/109	1	Rise and Fall Screw
130	1073/325	1	Rise and Fall Locking Tube
131	1073/324	1	Rise and Fall Locking Washer
132	1073/326	1	Rise and Fall Locking Spacer
133	SY20LX	1	'Y' Bearing Plummer Block Unit
134		2	M10 x 30 Long Hexagon Set Screws
135		2	10mm Washers
136	CP32/37	1	Rise and Fall Nut
137		1	1/4" Push in Flip up Straight Oiler
138	7100 025	1	25mm External Circlip
139	1041/88	1	Stop Washer for Rise and Fall Shaft
140		1	M6 x 16 Long Socket Capscrew
141	CP32/22	2	Trunnion Trapping Plate
142	CP32/23	2	Trunnion Slide
143		6	M8 x 25 Long Hexagon Set Screws
144		6	8mm Washers
145		4	6 Dia x 16 Long Groverlok Dowels
146		4	M8 x 20 Long Slotted Grubscrews
147		4	M8 Nuts

- ITEM NOT ILLUSTRATED

\* PLEASE QUOTE PART & MACHINE  
NUMBER WHEN ORDERING SPARES

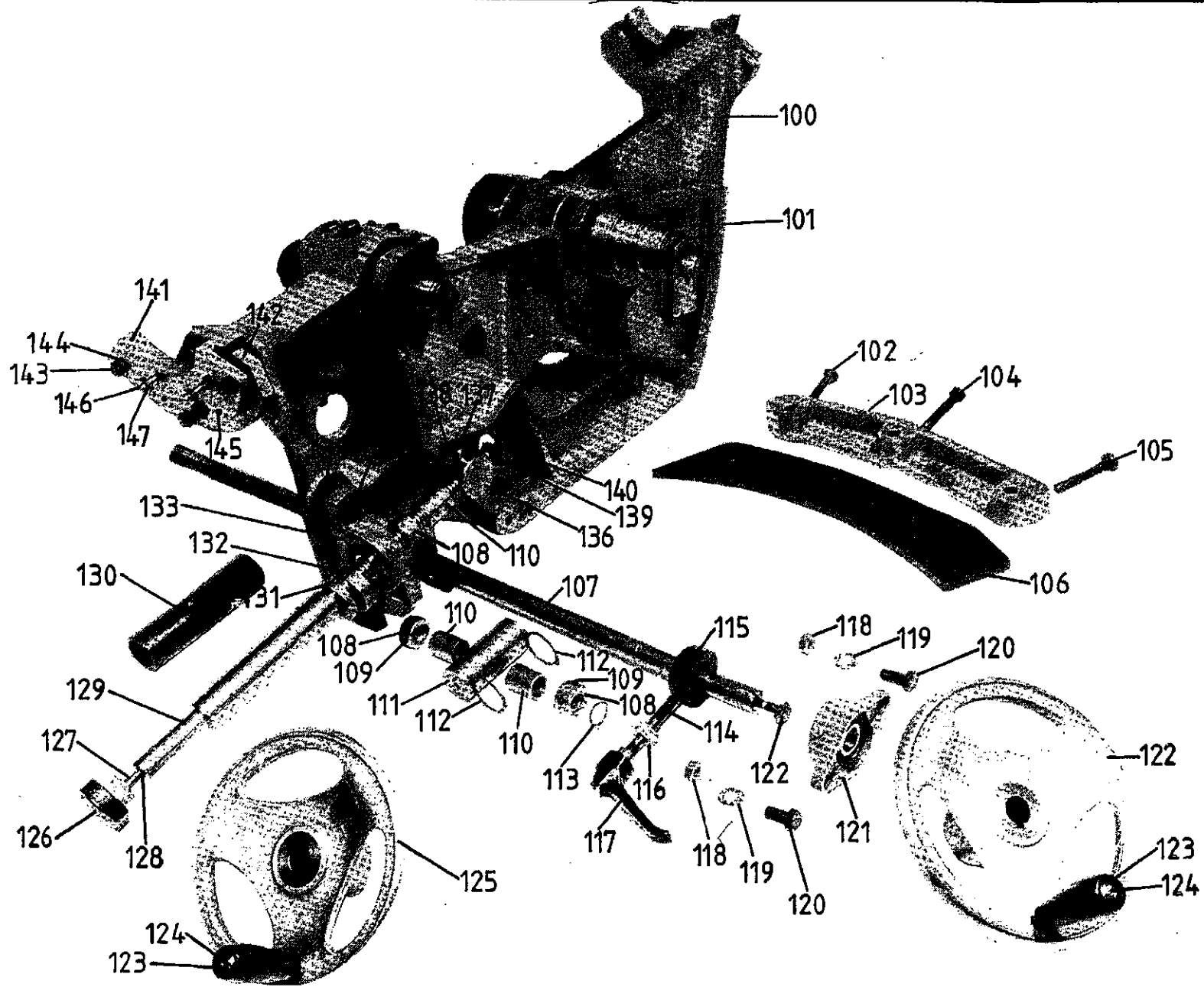

# Wadkin Bursgreen

## ILLUSTRATED PARTS LIST

### ASSEMBLY:- SAW MOTOR ASSEMBLY

FIG ITEM	PART NO. *	UNITS PER ASSEMBLY	DESCRIPTION
150		1	M10 x 30 Long Stud
151		13	10mm Washers
152		1	M10 Bristol Locking Handle
153		1	M10 x 35 Long Hexagon Set Screw
154		1	M12 x 1 $\frac{3}{4}$ " dia Tapped Ball
155		5	M10 Aerotight Nuts
156	1073/153	1	Motor Tension Lever
157	7100 012	2	12mm External Circlips
158		1	12mm x $\frac{3}{4}$ " x 1" Long Headless Pressfit Bush
159	1073/155	1	Motor Tension Bracket
160	CP32/42	1	Packing Piece for Motor (4kw-50 & 60 cycle only)
161		4	M10 x 25 Long Hexagon Set Screws
162	CP32/174	1	Motor Pulley (4KW & 5.5KW 50 CYCLE)
	CP32/176	1	Motor Pulley (5HP & 7 $\frac{1}{2}$ HP 60 CYCLE)
	CP32/173	1	Motor Pulley (7.5KW 50 CYCLE)
	CP32/175	1	Motor Pulley (10 HP 60 CYCLE)
163		2	M8 x 20 Long Socket Set Screws
164			
165		1	8 x 7 x 40 Long Feather Key
166	1073/42	1	Motor Platform
167	CP32/43	1	Mounting Plate for Motor (4kw - 50 & 60 cycle only)
168		2	M10 x 30 Long Hexagon Set Screws (4kw - 50 & 60 cycle only)
		2	M10 x 50 Long Hexagon Set Screws (5.5kw & 7.5kw - 50 & 60 cycle only)
169		2	M10 x 50 Long Stud (4kw - 50 & 60 cycle only)
170	No.8	12	Bellieville Washers
171		1	Brook D100L, Foot Mounted TEFC 4kw (5hp) 3000 rpm, 50 cycle Motor
		1	Brook D100L, Foot Mounted TEFC 5hp 3600 rpm, 60 cycle Motor
		1	Brook D112M, Foot Mounted TEFC 5.5kw 3 phase, 3000 rpm, 50 cycle Motor
		1	Brook D112M, Foot Mounted 7 $\frac{1}{2}$ hp, 3 phase 3600 rpm, 60 cycle Motor
		1	Brook D132Sa, Foot Mounted Motor 7.5kw 3 phase, 3000 rpm, 50 cycle Motor
		1	Brook D132M, Foot Mounted 10hp, 3 phase 3600 rpm, 60 cycle Motor
172	1073/156	1	Motor Guide Pin
173		2	M10 x 50 Long Countersunk Socket Screws
164	KSi-04-460	1	GATES POLYFLEX BELT 11 M 800 (4KW 50 CYCLE) (5HP & 7 $\frac{1}{2}$ HP 60 CYCLE)
	KSi-04-461	1	GATES POLYFLEX BELT 11 M 825 (5.5KW & 7.5KW 50 CYCLE) (10 HP 60 CYCLE).

- ITEM NOT ILLUSTRATED

\* PLEASE QUOTE PART &amp; MACHINE NUMBER WHEN ORDERING SPARES



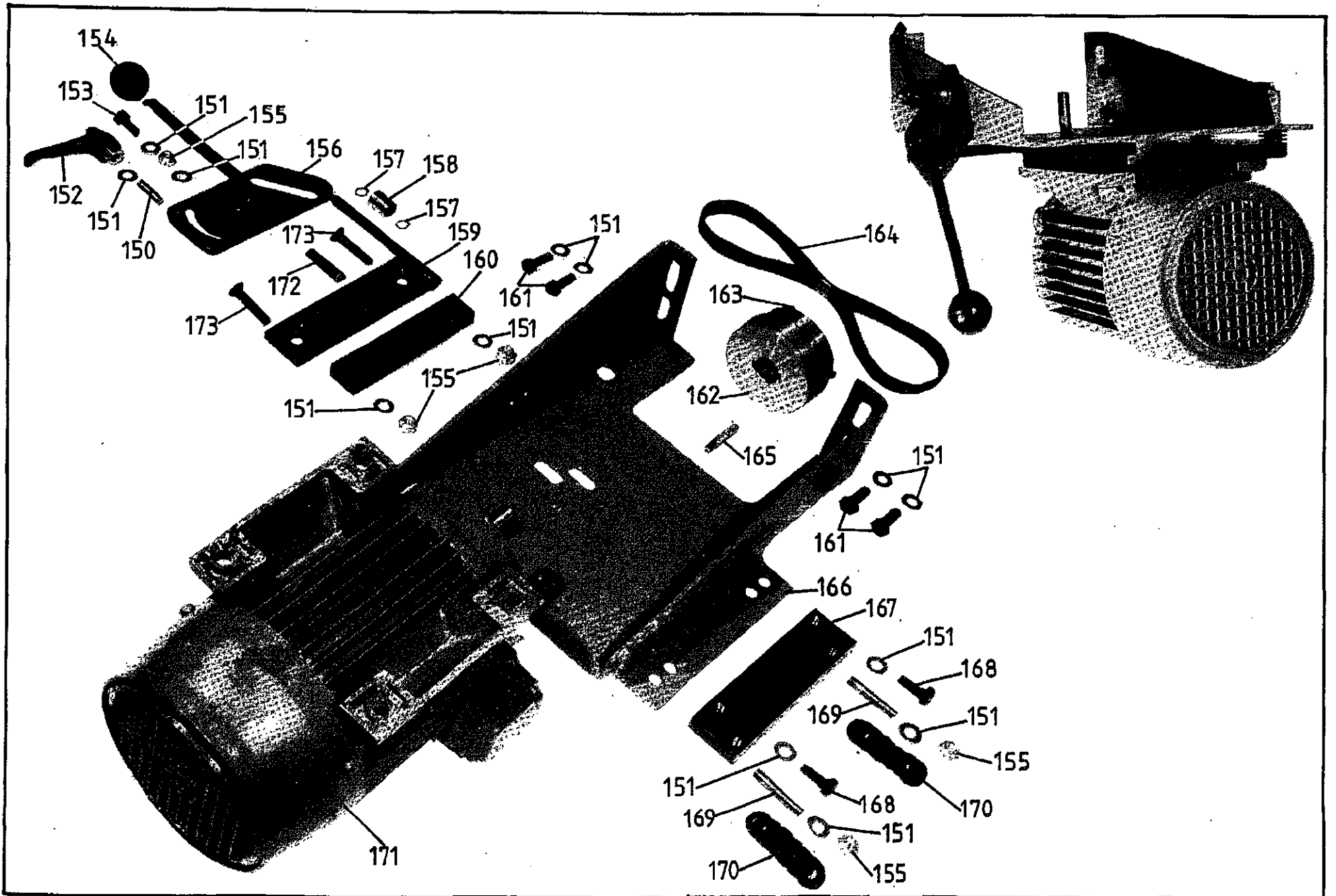

# Wadkin Bursgreen

## ILLUSTRATED PARTS LIST

ASSEMBLY:- MAIN SAW SPINDLE ASSEMBLY			
FIG ITEM	PART NO. *	UNITS PER ASSEMBLY	DESCRIPTION
180	7100 080	1	80mm External Circlip
181	1073/15	1	Riving Knife Pivot Bracket
182	1073/44	1	Spindle Housing
183		4	M10 x 30 Long Hexagon Set Screws
184	6206 2RS	2	Bearings
185	1030/183	1	Spindle Distance Piece
186	1073/139	1	Spindle Trapping Collar
187	1073/140	1	Spindle Locking Collar
188		2	M6 x 10 Long Socket Set Screws
189	1030/184	1	Saw Spindle Locknut
190	CP32/55	1	Spindle Pulley
191		1	8 x 7 x 55 Long Feather Key
192	CP32/38	1	Saw Spindle
193	CP32/54	1	Back Saw Flange
194	P32/254	1	Front Saw Flange (30mm dia Spindle)
	1030/75	1	30mm Spigot Bush
	P32/234	1	Front Saw Flange (1½" dia Spindle)
	P32/235	1	1½" Spigot Bush
195	1073/311	1	Saw Spindle Nut

ASSEMBLY:- SCORER MOTOR ASSEMBLY			
FIG ITEM	PART NO. *	UNITS PER ASSEMBLY	DESCRIPTION
200	CP32/13	1	Motor Platform
201	7100 010	2	10mm External Circlips
202	1073/68	1	Scoring Saw Motor Pivot Pin
203		3	M6 x 25 Long Coach Bolts
204		3	M6 Aerotight Nuts
205		1	Brook D71B Frame Motor 0.55kw, 3000rpm 415v, 50 cycle
206		1	6 x 6 x 32 Long Feather Key
207	CP32/21	1	Motor Pulley
208		2	M6 x 6 Long Socket Set Screws
209	460 J4	1	Poly-V-Belt

- ITEM NOT ILLUSTRATED

\* PLEASE QUOTE PART & MACHINE  
NUMBER WHEN ORDERING SPARES

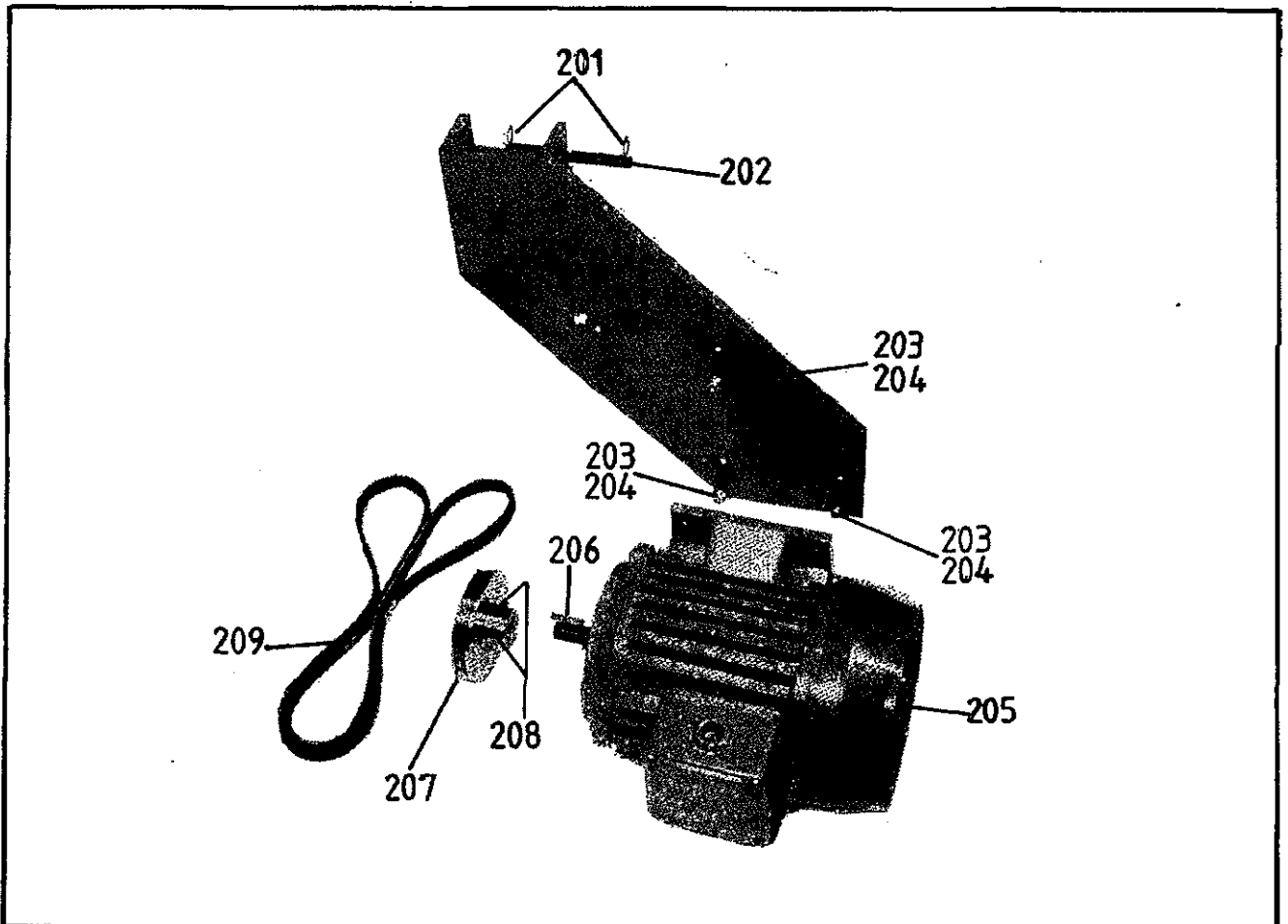
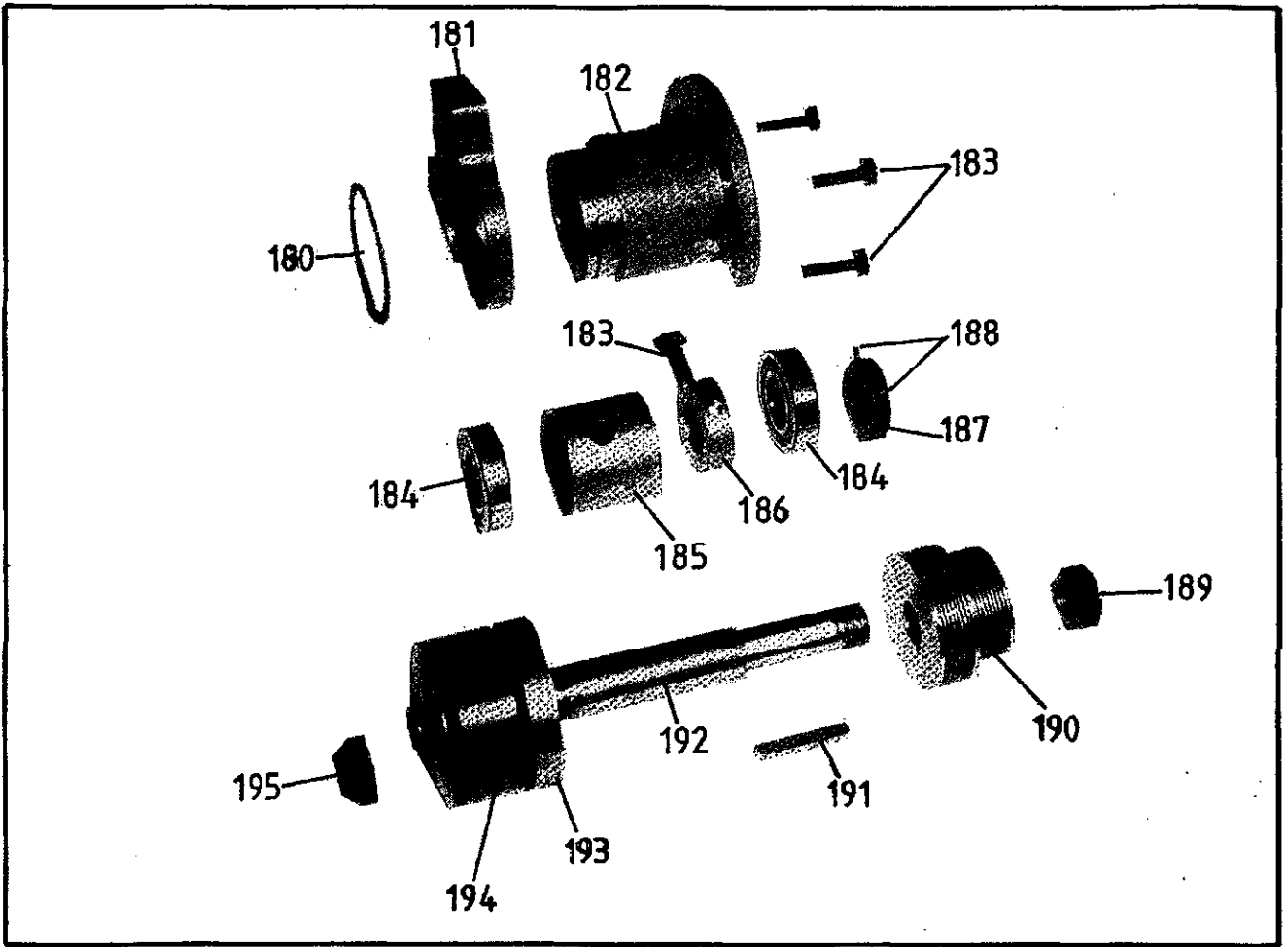

# Wadkin Bursgreen

## ILLUSTRATED PARTS LIST

### ASSEMBLY:- SCORING SAW ASSEMBLY

FIG ITEM	PART NO. *	UNITS PER ASSEMBLY	DESCRIPTION
215		1	M8 x 20 Long Nylock Socket Capscrew
216	1041/88	1	Washer for Spindle Pulley
217	CP32/20	1	Spindle Pulley
218	CP32/51	1	Spacer for Pulley
219		1	6 x 6 x 32 Long Feather Key
220	460 J4	1	Poly-V-Belt
221	7100 040	1	40mm External Circlip
222	1073/1	1	Rise and Fall Bracket
223		3	M8 x 12 Long Countersunk Socket Screws
224	1073/66	1	Rise and Fall Pivot Bracket
225	1073/334	1	Adjusting Screw for Scorer
226	S25/537	1	Lock Screw for Scorer
227	1073/336	1	Brass Bot for Scorer
228		1	M8 x 25 Long Socket Capscrew
229		2	M8 x 25 Long Socket Grubscrews
230	6003 2RS	2	Sealed for Life Bearings
231	CP32/45	1	Trunnion Bracket
232	ELP42	2	Bump Washer
233	ELP26	1	Bump Washer
234	1041/147	1	Shoe for Rise and Fall Quill
235	1073/27	1	Rise and Fall Quill
236	1073/62	1	Bearing Spacer
237		2	M5 x 8 Long Countersunk Socket Screws
238	1041/86	1	Rise and Fall Lever
239		1	Red PVC Plastic Handle
240	7000 035	1	35mm Internal Circlip
241	CP32/50	1	Saw Spindle
242	1041/77	2	Saw Flange
243	1041/76	1	Saw Spindle Nut

- ITEM NOT ILLUSTRATED

\* PLEASE QUOTE PART & MACHINE  
NUMBER WHEN ORDERING SPARES

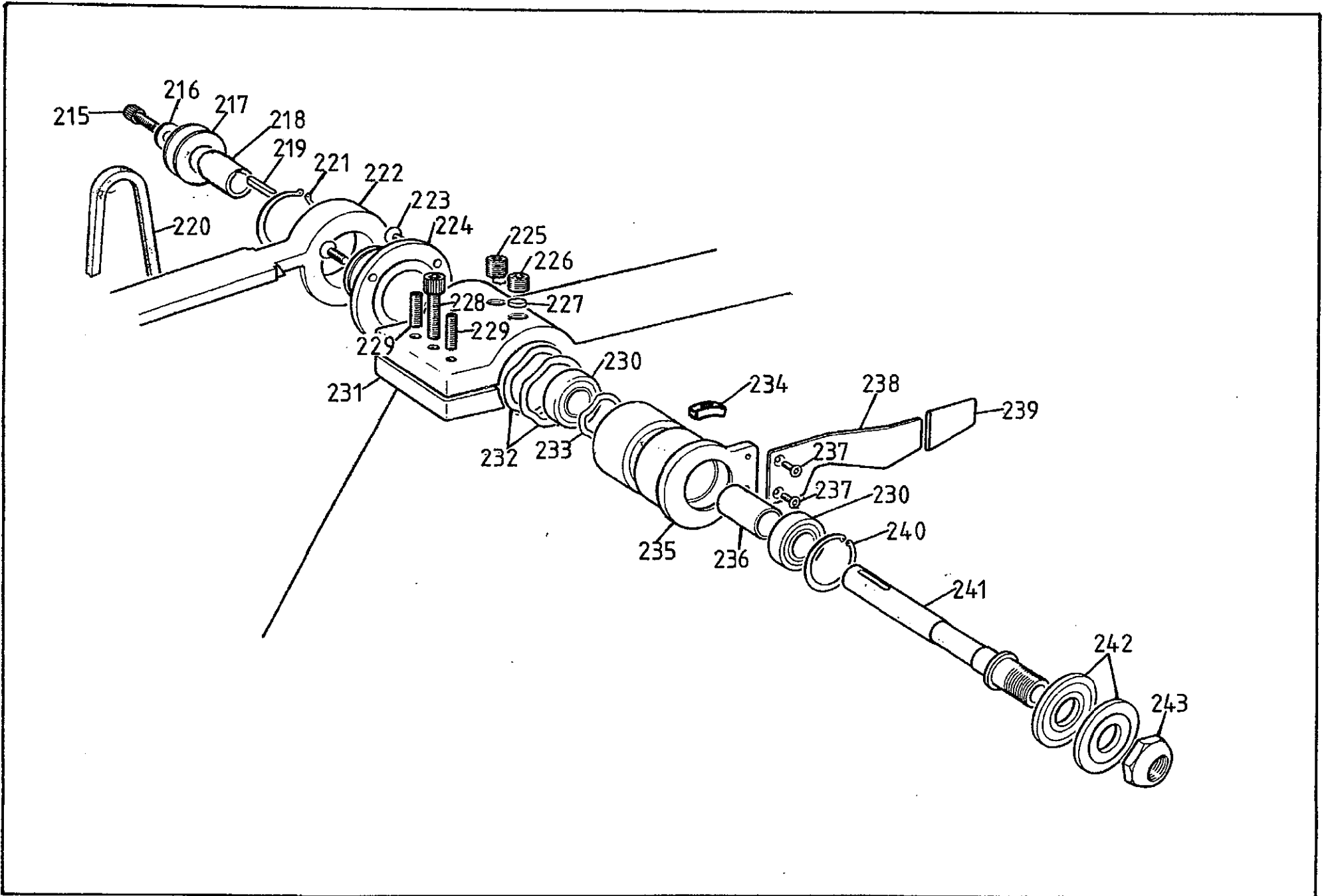

# Wadkin Bursgreen

## ILLUSTRATED PARTS LIST

### ASSEMBLY:- RIVING KNIFE ASSEMBLY

FIG ITEM	PART NO. *	UNITS PER ASSEMBLY	DESCRIPTION
250		1	M10 x 35 Long Hexagon Set Screw
251	1041/144	1	Sawguard
252		2	M10 x 40 Long Hexagon Set Screws
253	1073/15	1	Riving Knife Pivot Bracket
254		1	M10 Nut
255	CP32/17	1	Riving Knife Link Plate
256	CP32/48	1	Slide Bar
257		2	M8 x 35 Long Socket Button Head Screws
258	S25/369	1	Rear Clamp Plate
259	S25/359	1	Guide Plate
260	S25/368	1	Pressure Plate
261	S25/370	1	Front Clamp Plate
262	S25/537	1	M16 Locking Screw
263	P32/353	1	Riving Knife
264	S25/593	1	Sawguard Locking Handle
265	S25/396	1	Washer

### ASSEMBLY:- RIP FENCE

FIG ITEM	PART NO. *	UNITS PER ASSEMBLY	DESCRIPTION
270	CP12/3	1	Rip Fence Front Plate
271	S25/655	2	Studs for Rip Fence Front Plate
272	S25/631	1	Rip Fence
273		2	8mm Washers
274	K51-27-127	2	M8 Handwheels
275		1	M10 x 35 Long Hexagon Set Screws
276		3	10mm Washers
277	CP32/62	1	Rip Fence Support Bar
278	S25/60	1	Pointer
279	S25/638	1	Slide Bar for Pointer
280		1	M10 x 35 Long Nicked Grubscrew
281		2	M10 Nuts
282		4	M10 Locknuts
283		2	M10 x 65 Long Studs
284	P32/329	1	Rip Fence Bar
285		1	M6 x 10 Long Socket Capscrew
286	K51-27-137	1	8mm Handwheel
287		2	9 Bore x 14 <sup>0</sup> /Dia x 14 Long Oilite Bearings
288	S25/634	1	Pinion for Rip Fence
289		1	6 Dia Steel Ball
290	S25/635	1	Pinion Spring Retainer
291	ETS 18	1	Compression Spring
292	K51-27-139	1	M10 Handwheel
293		1	M10 x 60 Long Stud
294		2	M5 x 10 Long Pan Head Machined Screws
295	S25/64	1	Locking Plate

-- ITEM NOT ILLUSTRATED

\* PLEASE QUOTE PART & MACHINE  
NUMBER WHEN ORDERING SPARES

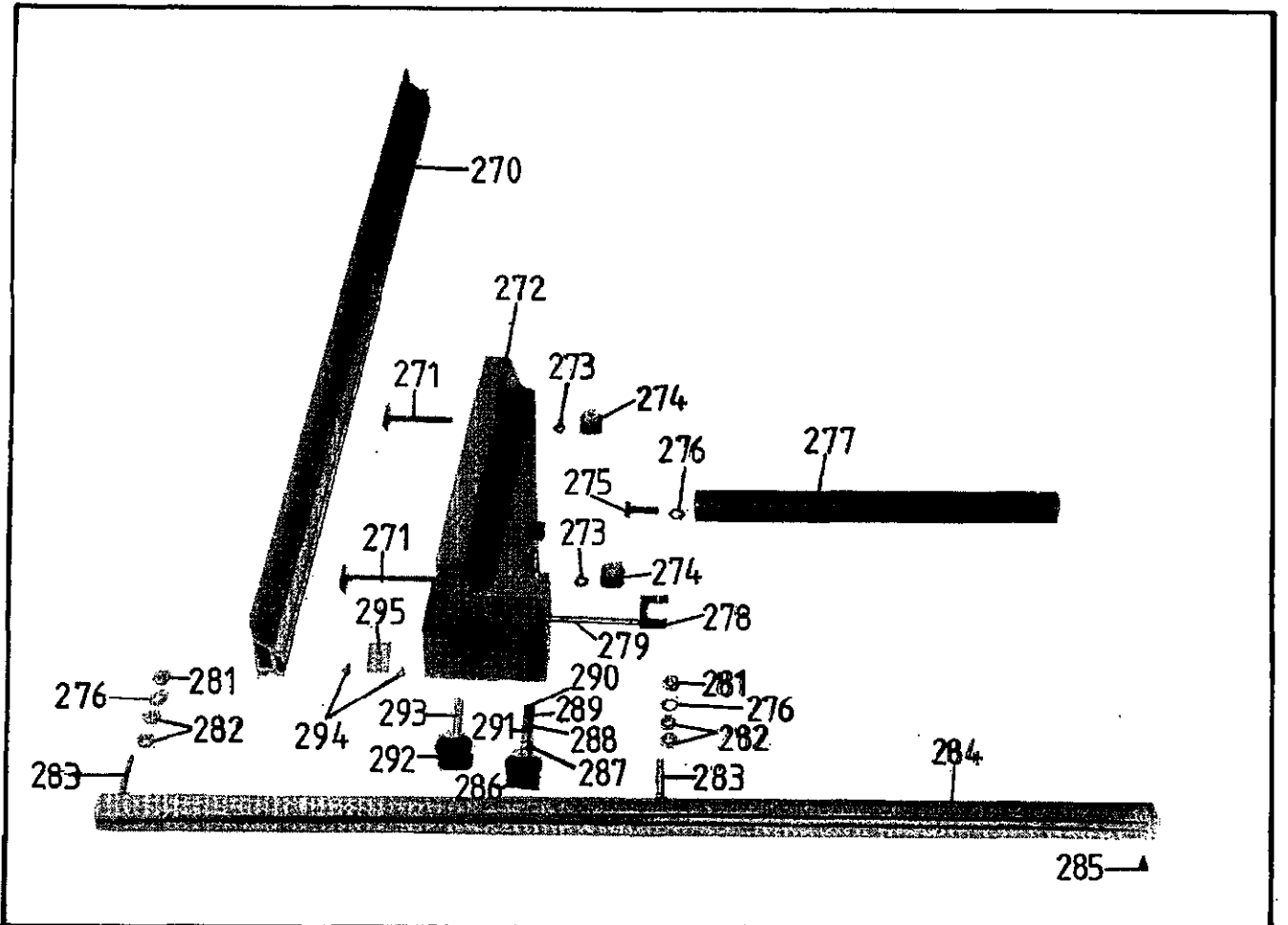
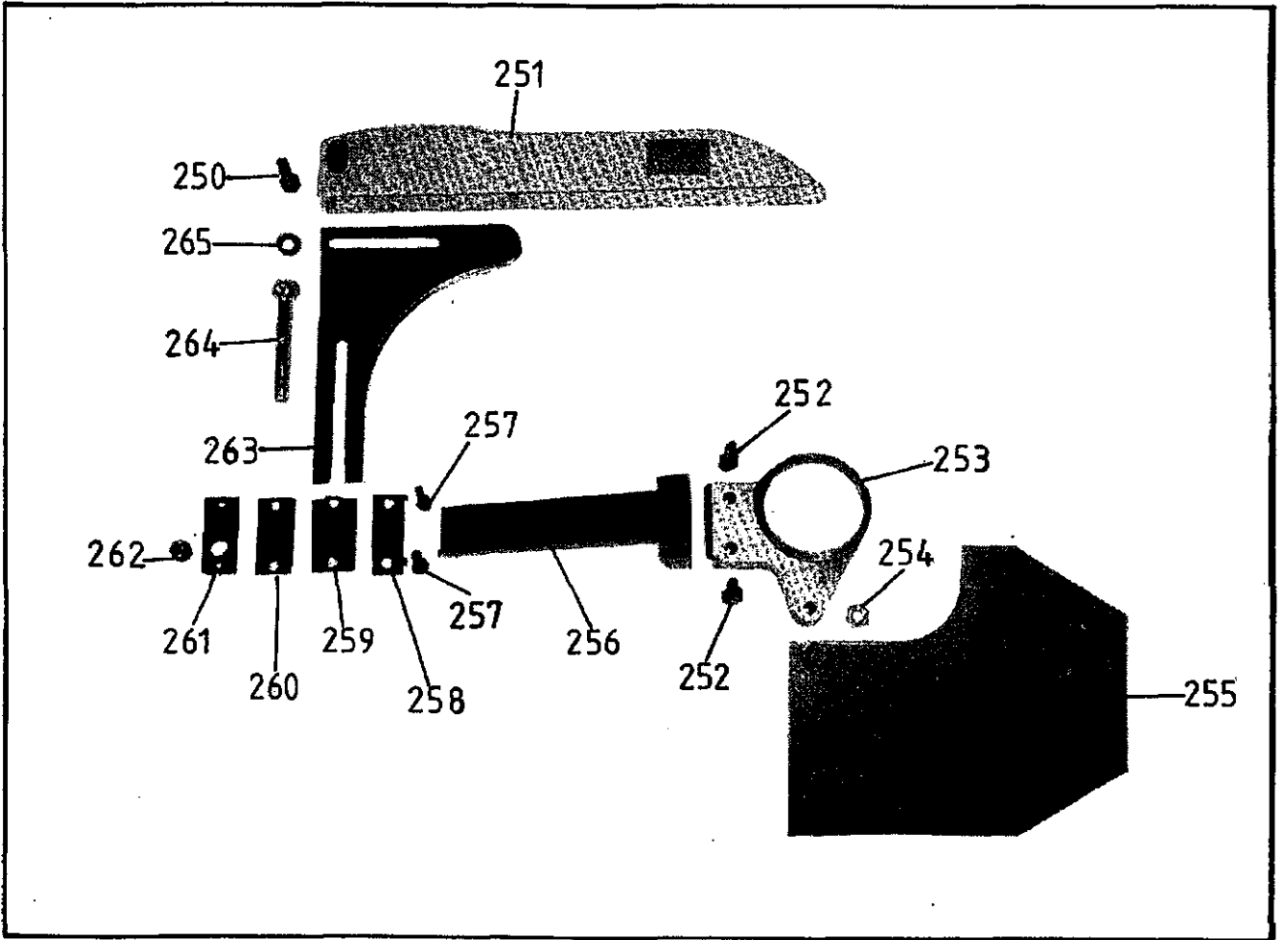

# Wadkin Bursgreen

## ILLUSTRATED PARTS LIST

### ASSEMBLY:- CROSSCUT FENCE

FIG ITEM	PART NO. *	UNITS PER ASSEMBLY	DESCRIPTION
300		1	M8 x 20 Long Hexagon Set Screw
301		1	8mm Washer
302	1073/347	2	Locking Boss for Extension
303		2	M6 x 6 Long Socket Set Screws
304	S25/418	1	Extension Support
305	S25/413	1	Fence Extension
306	S25/425	1	Extension Stop Bar
307		2	6mm Washers
308		2	M6 x 10 Long Socket Capscrews
309	S25/420	1	Crosscut Fence
310		1	M8 x 30 Long Stud
311	Patt 98	2	M8 Locking Knobs
312		1	M16 Aerotight
313		1	16mm Washer
314		1	5/8" Brass Washer
315		1	M10, x 35 Long Socket Set Screw
316	SP12/37	1	Pivot for Crosscut Fence
317	Patt 97	2	M6 Locking Knobs
318	S25/427	2	Shoe for Turnover Stop
319	1073/368	1	Turnover Stop Bracket RH
	1073/369	1	Turnover Stop Bracket LH
320	SP12/75	2	Button for Turnover
321	1073/371	1	Turnover Stop RH
	1073/400	1	Turnover Stop LH
322		2	12mm Brass Washers
323		4	M12 Locknuts
324	1041/157	1	Spring Distance Piece
325	1041/158	1	Spring for Locking Plunger
326		1	10 x 14 x 16 Long Oilite Bush
327		2	M6 x 16 Long Socket Capscrews
328		2	6mm Washers
329	1041/156	1	Fence Locking Plunger
330	1041/155	1	Plunger
331	1041/160	1	Bush for Sliding Table

- ITEM NOT ILLUSTRATED

\* PLEASE QUOTE PART & MACHINE  
NUMBER WHEN ORDERING SPARES



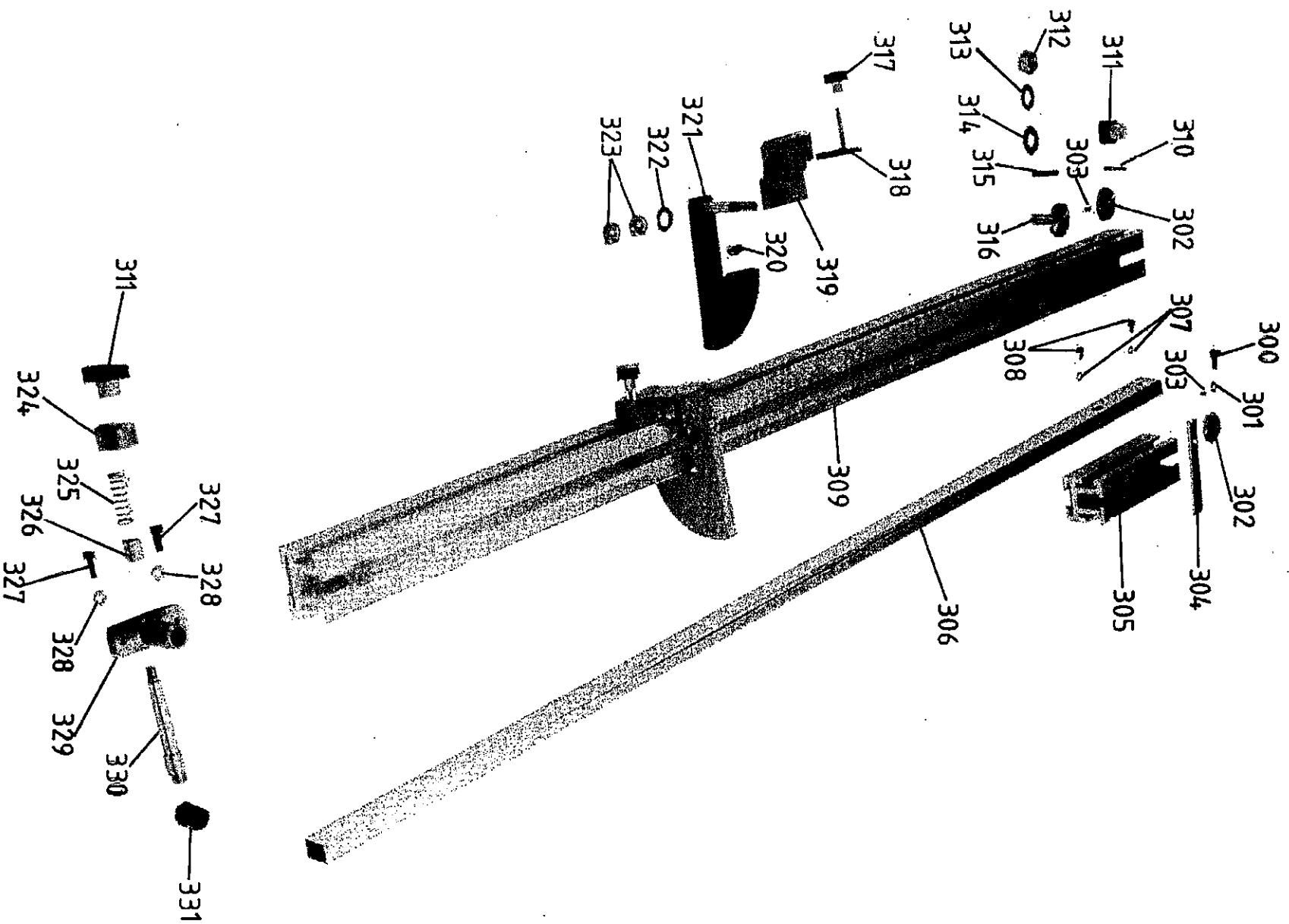

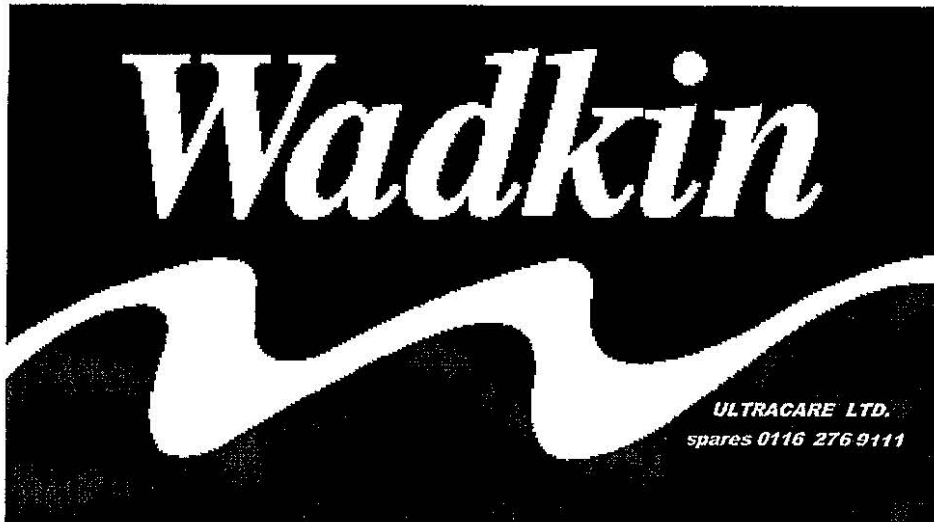

*Wadkin*

ULTRACARE LTD.  
spares 0116 276 9111