



Metric / Imperial

Dust Collection Hole x Suggested Power

∅125mm / ∅5" x 5HP

Pressure Roller / Dia.

6pcs / ∅70mm / ∅2.8"



Single Chain Conveyor

Cast Iron Guide Rails
9 V-shaped Ways

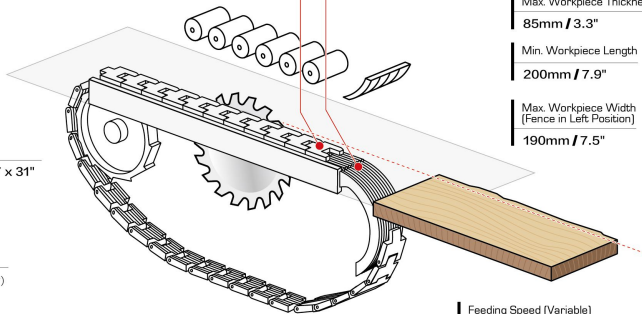

Table Surface

1700 x 800mm / 67 x 31"

Spindle Speed

4750rpm

Spindle Power

7.5HP (Optional 10HP)

Feeding Power

1HP (Optional 1HP Inverter)

Saw Blade Dia. x Bore

∅305mm x 25.4mm / ∅12" x 1"

Machine Size [L x W x H]

1950 x 1265 x 1430mm / 77 x 50 x 56"

Packing Size [L x W x H]

1990 x 1305 x 1530mm / 78 x 51 x 60"

N.W. / G.W.

973 / 1100kg / 2150 / 2430lbs

Max. Workpiece Thickness

85mm / 3.3"

Min. Workpiece Length

200mm / 7.9"

Max. Workpiece Width
(Fence in Left Position)

190mm / 7.5"

Feeding Speed [Variable]

12~24m/min / 39~79ft/min

Feeding Speed [Inverter]

11~26m/min / 36~85ft/min (Optional)



STRAIGHT LINE EDGERS
COMPACT SERIES

PU-12 XP

Wadkin
BURSGREEN



www.advancedmachinery.co.uk

Advanced Machinery Services Ltd
Skeffington Mill,
A47 Uppingham Road,
Skeffington, Leicestershire, LE7 9YE

Phone: 0844 844 9949
Fax: 0844 844 4744
Email: sales@advancedmachinery.co.uk



Advanced Machinery Services

Compact Straight Line Edger

User Experience

- Profile: Furniture manufacturer
- Configuration: 2 compact bottom rip saws in series
- Material: Pre-planed lumber on top and bottom surfaces
- Cutting dimensions: 90mm (W) x 50mm (H) x 1100mm (L)
- Capacity: 1090 PCS/hour @ 20m/min (Excluding loading time)

Finished Product: Beech Table Top

Perfect Jointing Accuracy!

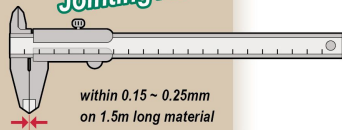

Machining Procedure

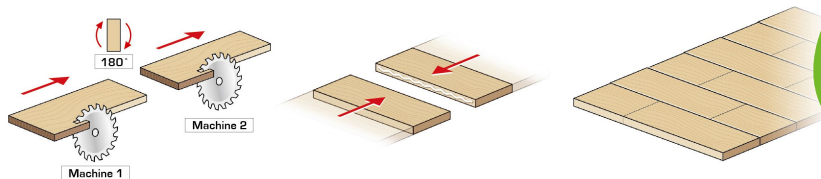

Sawing

Gluing

Assembly

CE Side Guard

Anti-kickback Fingers
(Bottom/Top) for Safer
Feeding Operations

Ruggedly Built Column
with Worm Gear System
for Elevation

CE Electrical
Cabinet, incl.
Safety Relay,
Emergency
Stop and
Power Lock

CE Locking System
for Access Door to
the Saw Blade

Robust Machine Body
Designed with Welded
Steel Frame

Light Fence for
Ripping Edges

Automatic Lubrication
for Chain Conveyor